

# L Series Hand Pull Valve (3/2,5/2 way)

# L

## Hand Pull Valve (3/2, 5/2)

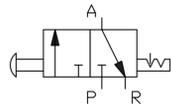

Hand pull valve (3/2)

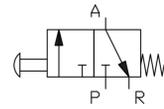

Hand pull valve (3/2 N.C.)

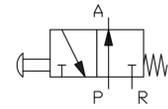

Hand pull valve (3/2 N.O.)

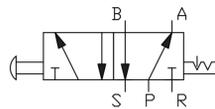

Hand pull valve (5/2)

### How to Order?

Series No.	Ways	Positions	Valve Body size	Port Size	Reset	Valve Color	Thread Type
L	3: 3 ways 5: 5 ways	2: 2 positions	1: 1 Series 2: 2 Series 3: 3 Series 4: 4 Series	1 Series 06: 1/8" 2 Series 06: 1/8" 08: 1/4"	3 Series 08: 1/4" 10: 3/8" 4 Series 10: 3/8" 15: 1/2"	Blank: Manual reset S: Spring return	Blank: Black W: White Blank: G P: PT T: NPT

#### Order Example:

L series hand pull valve, 3/2 way, 2 series valve body, NC type, 1/4" port size, manual reset, black valve body, G thread, ERP code is: L322-08

Remarks: Manual reset of two position tee can be divided into non opening and non closing

### Specifications

Model	L Series Hand pull valve
Working medium	Clean air (After 40 μm filtration)
Acting type	External control
Lubrication	Not required
Working pressure (MPa)	0~0.8
Guaranteed pressure (MPa)	1.2
Working temperature(°C)	-5~60

### Product Features

- \* Manual operated
- \* Various working styles are available
- \* Black color is standard color, different color are optional

### Main Dimension

L321/L322/L323/L324

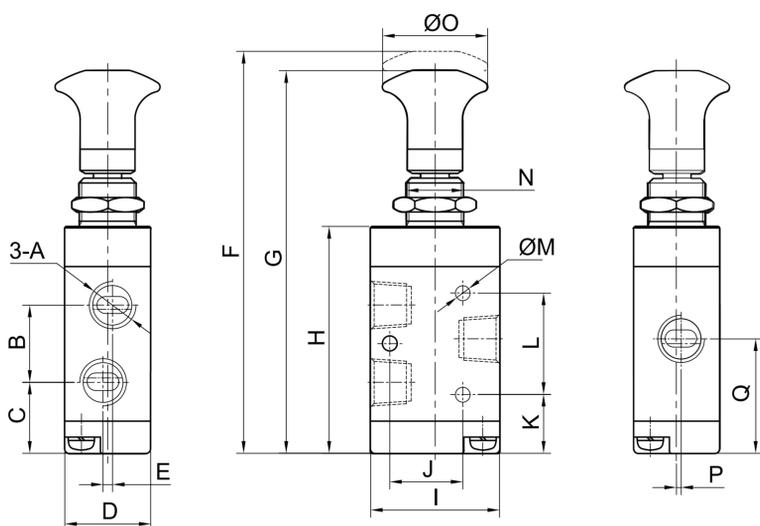

Model/Sign	L321	L322-06	L322-08	L323-08	L323-10	L324-10	L324-15
A	G1/8	G1/8	G1/4	G1/4	G3/8	G3/8	G1/2
B	16	18.5	22.5	22	24	31.5	31.5
C	14.7	18.45	16.45	21.5	20.5	29.25	29.3
D	18	22	22	27	27	34	34
E	2	0	0	0	2	0	0
F	84.5	94	94	111.3	111.3	141	141
G	80.5	89.7	89.7	105.7	105.7	136	136
H	44.7	54.7	54.7	63.5	63.5	87.5	87.5
I	27	35	35	40	40	50	50
J	19	24	24	28	28	36	36
K	15.7	17.7	17.7	20.5	20.5	31	31
L	16.7	20	20	24	24	28	28
M	3.1	4.3	4.3	4.3	4.3	5.5	5.5
N	M14x1	M14x1	M14x1	M14x1	M14x1	M22x2.5	M22x2.5
O	22.4	22.5	22.4	32	32	32	32
P	1	0	1.5	0	2	2	2
Q	23.7	27.7	28.7	32.5	32.5	45	45

# L Series Hand Pull Valve (3/2,5/2 way)

## Main Dimension

L521/L522/L523/L524

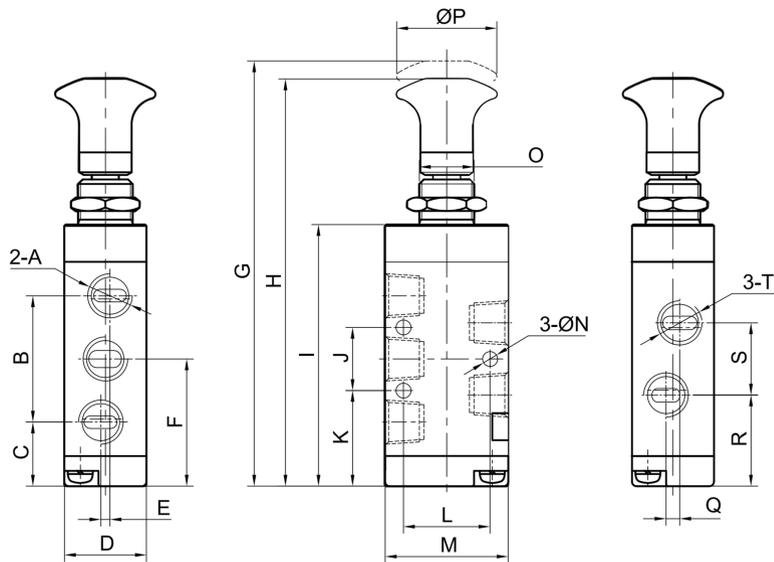

Model/ Sign	L521	L522 -06	L522 -08	L523 -08	L523 -10	L524 -10	L524 -15
A	G1/8	G1/8	G1/8	G1/4	G1/4	G3/8	G1/2
B	28	35	35	45	45	63	63
C	14.2	14.2	14.2	17.5	17.5	25.5	25.5
D	18	22	22	27	27	34	34
E	1	0	0	0	4	0	0
F	28.2	31.7	31.7	40	40	57	57
G	95.5	102	102	126.3	126.3	165	165
H	91.5	98	98	120.7	120.7	160	160
I	55.7	62.7	62.7	78.5	78.5	111.5	111.5
J	14	20	20	24	24	28	28
K	21.2	21.7	21.7	28	28	43	43
L	19	24	24	28	28	36	36
M	27	35	35	40	40	50	50
N	3.3	4.3	4.3	4.3	4.3	5.5	5.5
O	M14x1	M14x1	M14x1	M14x1	M14x1	M22x1.5	M22x1.5
P	22.5	22.5	22.5	32	32	32	32
Q	3	0	3	0	4	0	4
R	20.2	22.7	21.7	28	28	39	39
S	16	18	20	24	24	36	35.5
T	G1/8	G1/8	G1/4	G1/4	G3/8	G3/8	G1/2