

SZB series Universal Corrugated Suction Cups



SZB

Universal Corrugated Suction Cups



Product Features

- 1.5 Fold corrugated suction cups.
- Seal lip soft and taper.
- Bottom with support structure.
- Top with clamps.
- Complete size specifications.
- Compensate the height difference of the workpiece, and have a good buffer effect when contacting the workpiece.
- The workpiece with uneven surface has good sealing.
- Handling thin-walled workpieces will not cause permanent deformation.
- Prevent the suction cup and the suction cup joint from loosening or falling off.
- Suitable for various sizes and shapes of the workpiece.
- Suitable for handling workpiece with uneven surface, such as carton, cardboard, curved workpiece, pipe, etc.
- Suitable for handling fragile workpieces, such as electronic components, injection parts, etc.
- Suitable for handling smooth wood, smooth steel plate, etc.

How to order?

Series NO.	Size Specification	Sucker Material	Connection Specification
SZB: SZB Series		N: nitrile rubber S: Silicone rubber WS: White silicone rubber CS: conductive silicone rubber	Blank: single sucker M5M: M5x0.8 external thread G1M: G1/8 external thread G2M: G1/4 external thread G3M: G3/8 external thread G1F: G1/8 internal thread G2F: G1/4 internal thread G3F: G3/8 internal thread G4F: G1/2 internal thread
	5: Φ5mm 20: Φ20mm 6: Φ6mm 30: Φ30mm 8: Φ8mm 40: Φ40mm 10: Φ10mm 50: Φ50mm 12: Φ12mm 75: Φ75mm 15: Φ15mm 110: Φ110mm 17: Φ17mm 150: Φ150mm		

Ordering Example: SZB series universal corrugated suction cup, size specification 30, Buqing rubber, connection specification: G1/8 external thread. Its order code is: SZB30N-G1M

Model Number	Connection specification M-external thread	F- Internal thread
SZB5□	SZB6□-M5M	-
SZB6□	SZB8□-M5M	-
SZB8□	SZB10□-M5M	-
SZB10□	SZB12□-M5M	-
SZB12□	SZB15□-M5M	-
SZB15□	SZB17□-M1M	SZB15□-M5M
SZB17□	SZB20□-M1M	SZB17□-G1F
SZB20□	SZB30□-M1M	SZB20□-G1F
SZB30□	SZB40□-M1M	SZB30□-G1F
SZB40□	SZB50□-M2M	SZB40□-G1F
SZB50□	SZB50□-M3M SZB50□-M5M	SZB50□-G2F SZB50□-G3F
SZB75□	-	SZB75□-G2F
SZB110□	-	SZB110□-G4F
SZB150□	-	SZB150□-G4F

Structure

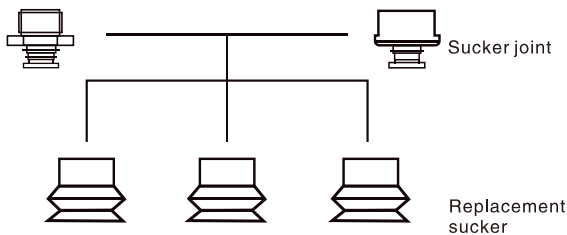

1.5 Corrugated structure design, large compression stroke. Suction cup and joint split structure design, can be replaced separately wearing parts.

In the same series, replacement suckers and suckers couplings can be combined on request.

Performance Parameter

Model Number	Pulling Force(N)	Internal Volume(cm ³)	Minimum rate of workpiece(mm)	Weight (g)	Recommended hose(mm)	Minimum package(pcs)
SZB5	0.8	<0.1	8	0.3	4	10
SZB6	1.2	<0.1	8	0.5	4	10
SZB8	2.1	<0.1	10	0.4	4	10
SZB10	3.2	0.4	12	0.9	4	10
SZB12	4.7	0.8	15	1.5	6	10
SZB15	7.4	0.5	20	1.5	6	10
SZB17	9.5	1.1	25	1	6	10
SZB20	18	1.2	30	3	6	5
SZB30	33	14	35	7.5	6	5
SZB40	60	18	50	13	6	5
SZB50	92	26	80	24	8	1
SZB75	210	96	60	68	8	1
SZB110	412	314	120	178	12	1
SZB150	740	798	160	439.5	12	1

Note: Measuring vacuum -60kPa workpiece surface is smooth and clean. The above pull-out force data do not include the safety factor. Depending on the surface condition of the workpiece, the value may change. It is recommended that the vacuum tube be as short as possible, with the length not exceeding 2m.

SZB series Universal Corrugated Suction Cups

◎ Main Dimension (mm)

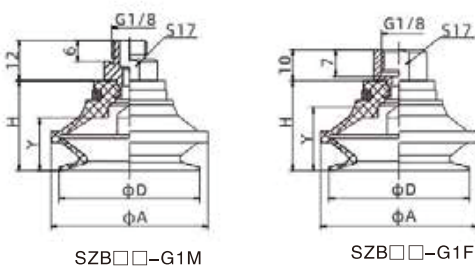
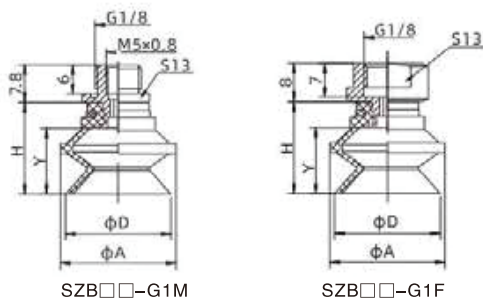
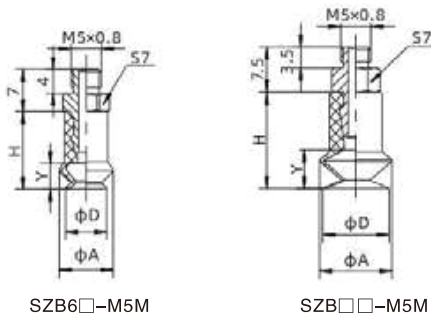
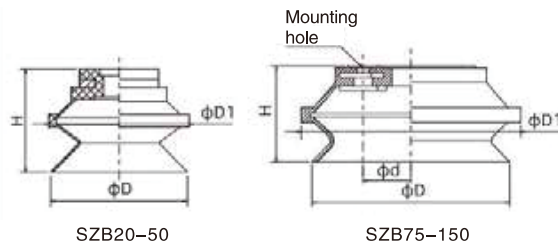
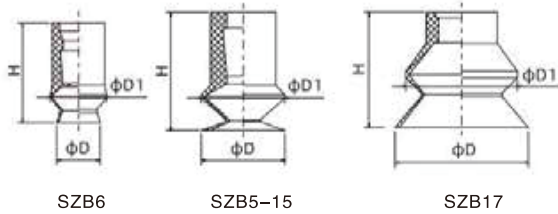

Model/Size	D	D1	H
SZB5□	5.8	6.2	9.2
SZB6□	7	9	13.5
SZB8□	8.8	9.6	11.9
SZB10□	11	12	16
SZB12□	12	14	16.5
SZB15□	15.5	17.5	19.5
SZB17□	18.5	16.6	15.6

Model/Size	D	D1	H	d	Mounting hole
SZB20□	22	24	19	-	-
SZB30□	34	36	26	-	-
SZB40□	43	46	28	-	-
SZB50□	53	58	35	-	-
SZB75□	78	83	37	35	4- ϕ 6.5
SZB110□	115	124	54	55	8- ϕ 6
SZB150□	155	166	71	70.5	8- ϕ 6

Model/Size	D	A	H	Y
SZB5□-M5M	5.8	6.2	9.2	3.6
SZB6□-M5M	7	9	13.5	4.5
SZB8□-M5M	8.8	9.6	11.9	6.5
SZB10□-M5M	11	12	16	7
SZB12□-M5M	12	14	16.5	5.5
SZB15□-M5M	15.5	17.5	19.5	10

Model/Size	D	A	H	Y
SZB17□-G1M	18.5	16.6	15.6	10.5
SZB17□-G1F	18.5	16.6	15.6	10.5
SZB20□-G1M	22	24	19	9
SZB20□-G1F	22	24	19	9

Model/Size	D	A	H	Y
SZB30□-G1M	34	36	26	19
SZB30□-G1F	34	36	26	19
SZB40□-G1M	43	46	28	20
SZB40□-G1F	43	46	28	20

SZB series Universal Corrugated Suction Cups



◎ Main Dimension (mm)

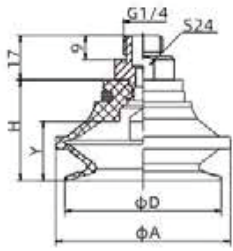

SZB50□-G2M

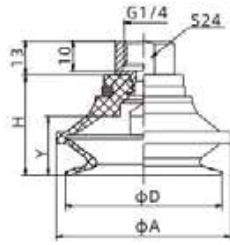

SZB50□-G2F

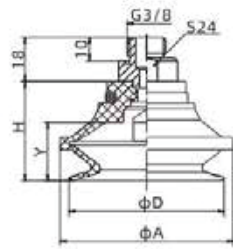

SZB50□-G3M

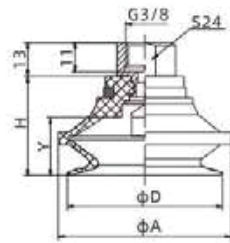

SZB50□-G3F

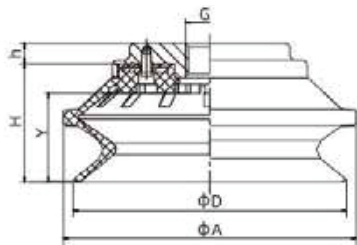

SZB75-150

Model/Size	D	A	H	Y
SZB50□-G2M	53	58	35	20
SZB50□-G2F	53	58	35	20

Model/Size	D	A	H	Y
SZB50□-G3M	53	58	35	20
SZB50□-G3F	53	58	35	20

Model/Size	D	A	H	h	G	Y
SZB75□-G2F	78	83	37	13	G1/4	27
SZB110□-G4F	115	124	54	9	G1/2	38.5
SZB150□-G4F	155	166	71	10	G1/2	44.5

◎ Parts Selection Specification

Model	Type specification M- External thread	F-Internal thread	Adapter
Sucker joint	PJS-M5M-SC1	-	SZB6
	PJS-M5M-SF2	-	SZB5、 8
	PJS-M5M-SF3	-	SZB10、 12、 15
	PJS-G1M-SF1	PJS-G1F-SF1	SZB17、 20
	PJS-G1M-SF2	PJS-G1F-SF2	SZB30、 40
	PJS-G2M-SF3	PJS-G2F-SF3	SZB50
	PJS-G3M-SF3	PJS-G3F-SF3	SZB50
	-	PJS-G2F-SF75	SZB75
	-	PJS-G4F-SF110	SZB110
	-	PJS-G4F-SF150	SZB150