

## AEFR/BEFR

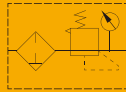

### How to Order?

Series No.	Type Code	Body Size	Pressure Gauge Code	Bracket Code	Scale Unit	Thread Type
AE: Small body size without bowl guard BE: Larger body size with bowl guard	FR: Regulator+Filter	1500: 1/8" 2000: 1/4" 3000: 3/8" 4000: 1/2"	Blank: With pressure gauge N: No pressure gauge	Blank: With bracket J: No bracket	4: Mpa/Psi(Default) 5: Bar/Psi	Blank: G P: PT T: NPT

#### Order Example:

AE series Filter+regulators, 1/4" body size, Mpa/Psi pressure scale unit, PT thread, ERP code is: AEFR2000-4-P

### Main Dimension

AEFR1500/2000

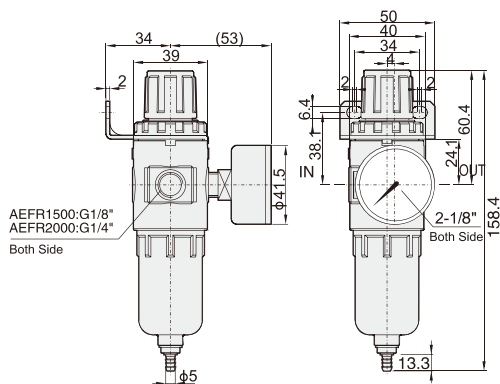

BEFR2000-4000

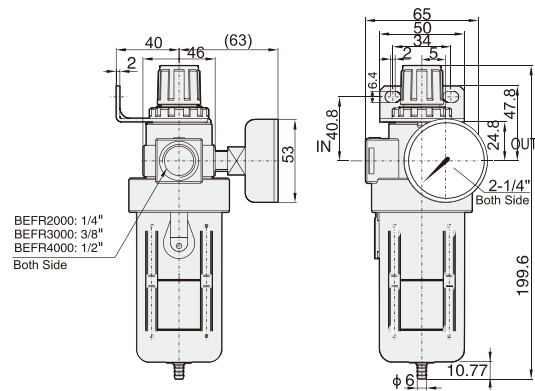

### Specifications

Model	AEFR1500	AEFR2000	BEFR2000	BEFR3000	BEFR4000
Working medium	Air				
Port size	G1/8	G1/4	G1/4	G3/8	G1/2
Filter precision	40 μm ( 5, 50 μm is optional )				
Adjusting pressure range (MPa)	0.15-0.85				
Max. adjusting pressure (MPa)	1.0				
Guaranteed. pressure (MPa)	1.5				
Working temperature(°C)	5-60				
Filter bowl capacity (CC)	15		60		
Weight (g)	260		400		