

# SHL Wide Type Parallel Style Air Gripper

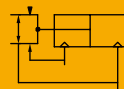

## SHL

Wide Type Parallel Style Air Gripper



### Specification



Bore Size(mm)	16	20	25	32
Acting Type	Double acting			
Fluid	Air(to be filtered by 40 μm or better)			
Operating pressure	0.15~0.7MPa(22~100psi)(1.5~7bar)			
Temperature°C	-20~70( No freezing)			
Lubrication	Cylinder:No necessary			
Max.frequency	40 cycle/minute			20 cycle/minute
Gripping force(N) ①	45	74	131	228
Proof pressure	1.2MPa(175psi)			
Repeatability(mm)	±0.1			
Cushion type	Bumper			
Port Size	M5X0.8			G1/8②

① Gripping force is 40mm(φ16~φ25) or 80mm(φ32) at 0.5 MPa

② G、PT、NPT thread Optional

### How to order?

Series	Bore	X	Stroke	—	Magnet No	□ (缸径32)
SHL: Wide air gripper (Double acting)	16 20 25 32		Listed below		S:With magnet (Magnet is standard)	Blank: G P: PT T: NPT

#### Order Example:

SHL Series air gripper, Bore 25mm, Stroke 60mm, With magnet, ERP code is: SHL25X60-S

### Stroke

Bore(mm)	Standard Stroke(mm)	Max.Stroke(mm)
16	30 40 60 80	80
20	40 60 80 100	100
25	40 60 80 100	100
32	60 80 100 150	150

### Product feature

- 1.The gripper opening or closing can be precisely synchronized with the rack & pinion mechanism.
2. Two round and two square Slots on the barrel, Multiple magnet switch are available.
- 3.Multiple bore size and stroke are available.
- 4.Double pistons design to increase the clamping force.
- 5.Multiple options for installing and fixing .
- 6.Convenience to mount workpiece.
- 7.Design for large workpiece.
- 8.Magnet is included in the standard configuration.

### Internal Structure

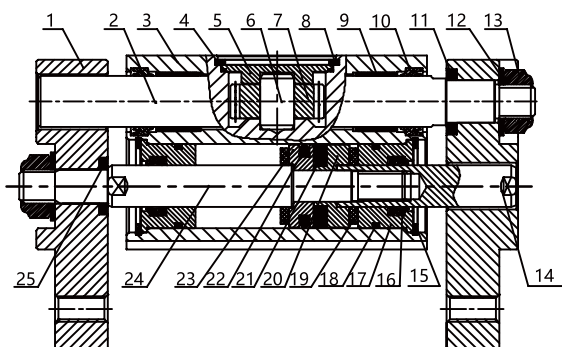

No.	Part Name	Material	No.	Part Name	Material
1	Face plate	Aluminum alloy	14	Piston rod B	Stainless steel
2	Rack	Stainless steel	15	C Type retaining ring	Spring steel
3	Bore	Aluminum alloy	16	Piston rod seal	NBR
4	O-ring	NBR	17	Head cover	Aluminum alloy
5	Gear cover	Aluminum alloy	18	O-ring	NBR
6	Gear axes	Stainless steel	19	Bumper	TPU
7	Gear	Mould steel	20	Magnet seat	Aluminum alloy
8	C Type retaining ring	Spring steel	21	Magnet	Sintered metal (Neodymium-iron-boron)
9	Bearing	Wear resistant material	22	Piston seal	NBR
10	Piston rod seal	NBR	23	Piston	Aluminum alloy
11	Washer	Carbon steel	24	Piston rod A	Stainless steel
12	Washer	Stainless steel	25	Washer	Carbon steel
13	Nut	Stainless steel			

◎ 外形尺寸图

SHL16

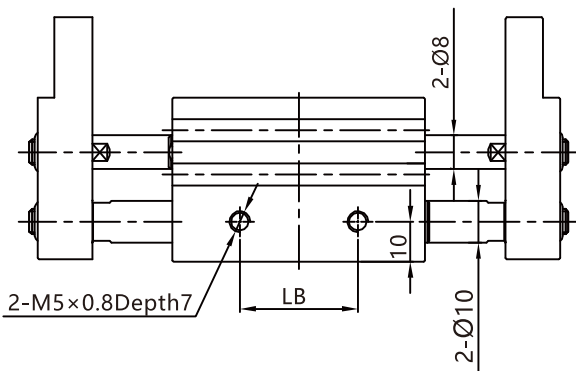
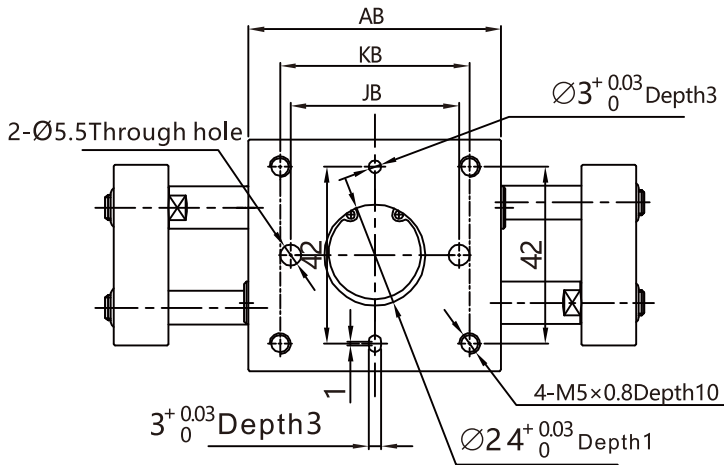
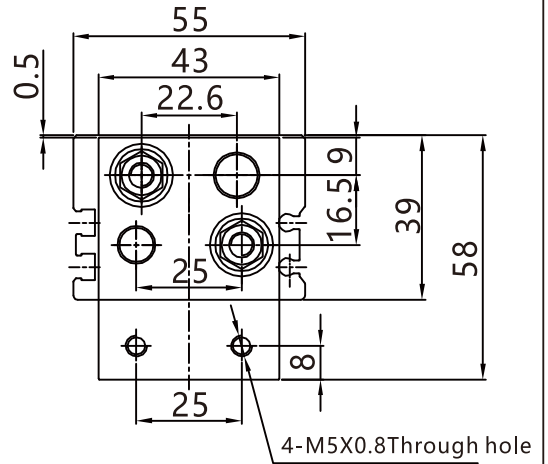
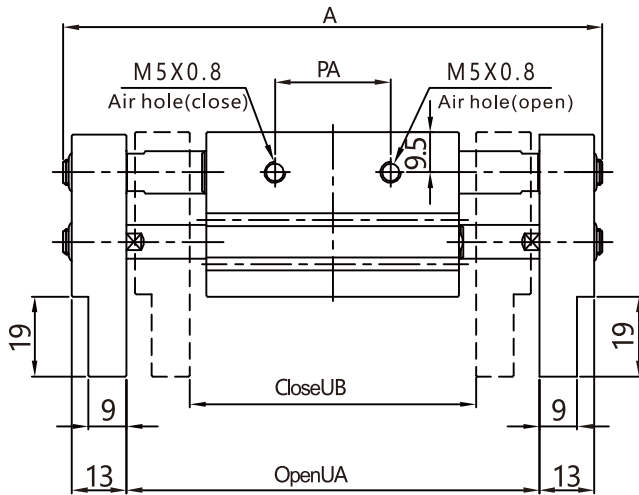

Sign/Bore	30	40	60	80
A	128	148	194	234
AB	60	70	90	110
JB	40	50	70	90
KB	45	55	75	95
LB	28	38	58	78
PA	25	30	40	51.6
UA(Open )	98	118	164	204
UB ( Close )	68	78	104	124

# SHL Wide Type Parallel Style Air Gripper



## 外形尺寸图

SHL20

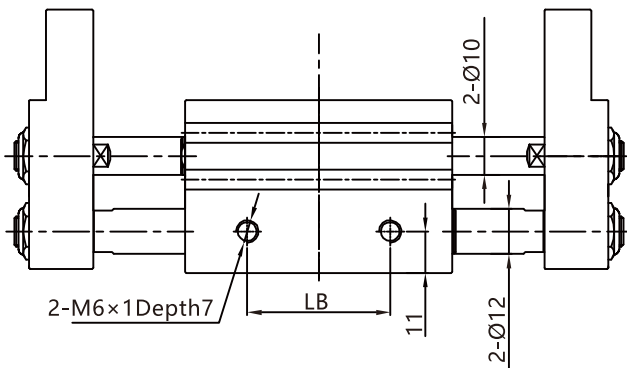
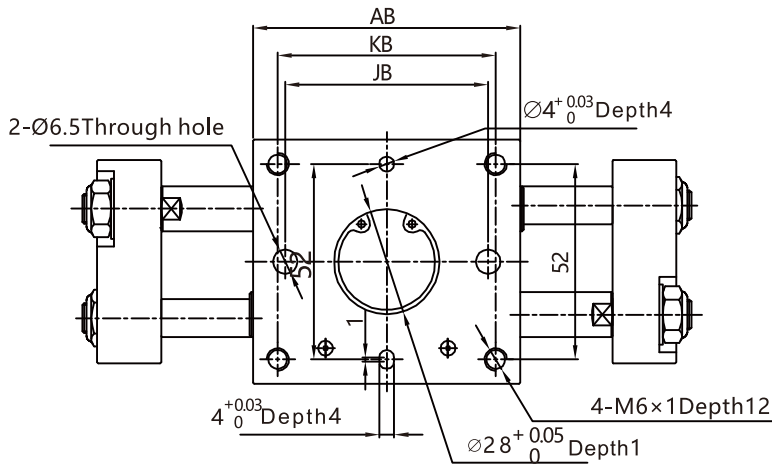
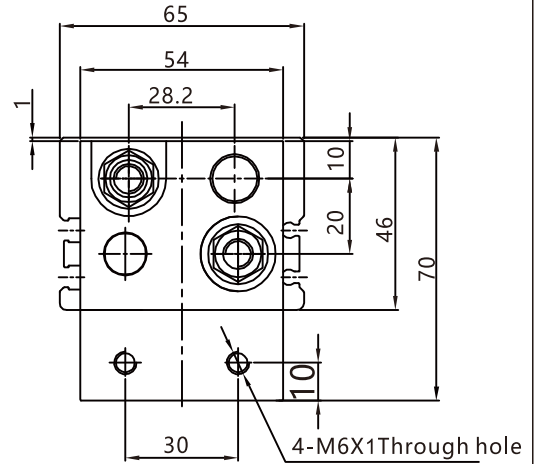
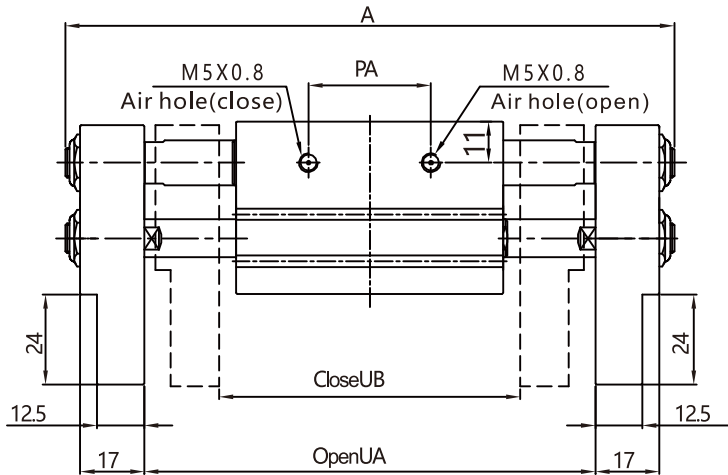

Sign/Bore	40	60	80	100
A	162	202	254	294
AB	71	91	113	133
JB	54	74	96	116
KB	58	78	100	120
LB	38	58	80	100
PA	32.6	42.6	52.6	64
UA(Open)	120	160	212	252
UB (Close)	80	100	132	152

## 外形尺寸图

SHL25

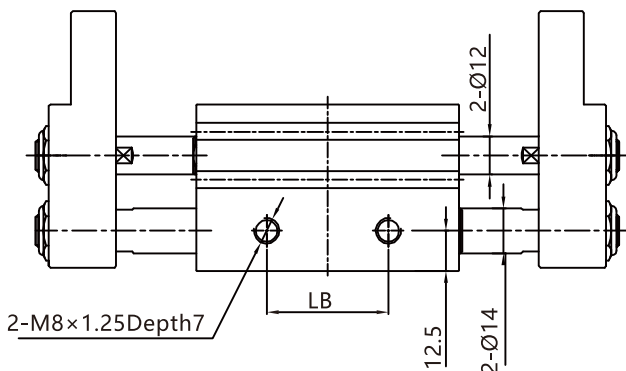
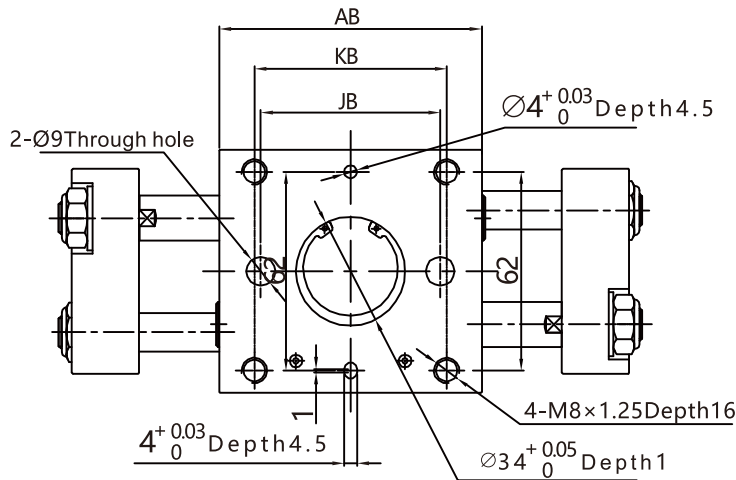
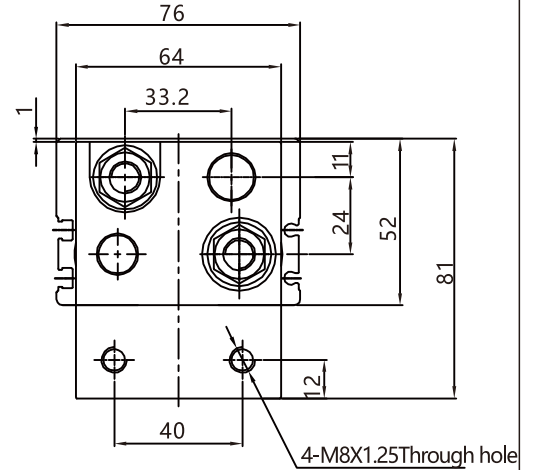
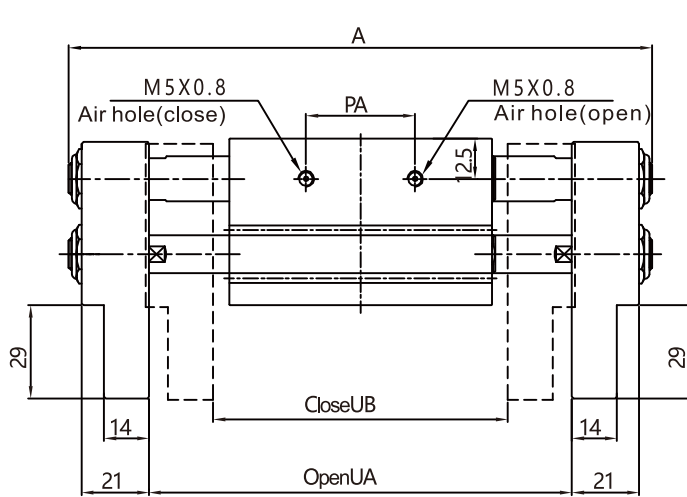

Sign/Bore	40	60	80	100
A	182	222	276	316
AB	82	102	122	142
JB	56	66	100	120
KB	60	70	104	124
LB	38	48	82	102
PA	34	44	54	64
UA(Open)	132	172	226	266
UB(Close)	92	112	146	166

# SHL Wide Type Parallel Style Air Gripper



## 外形尺寸图

SHL32

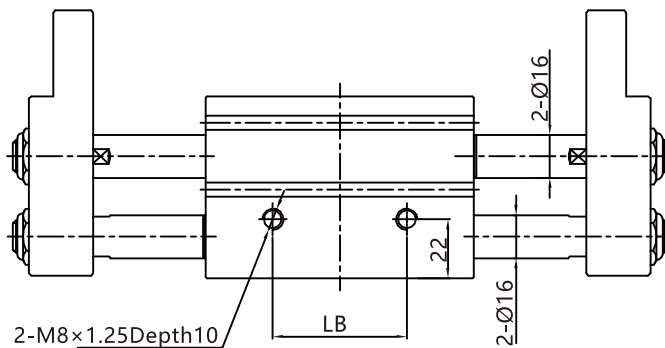
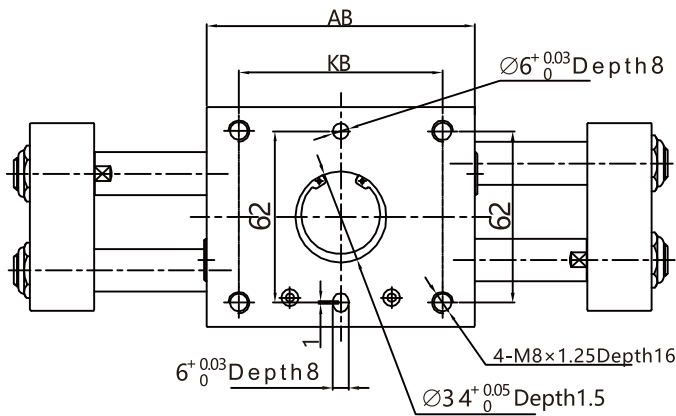
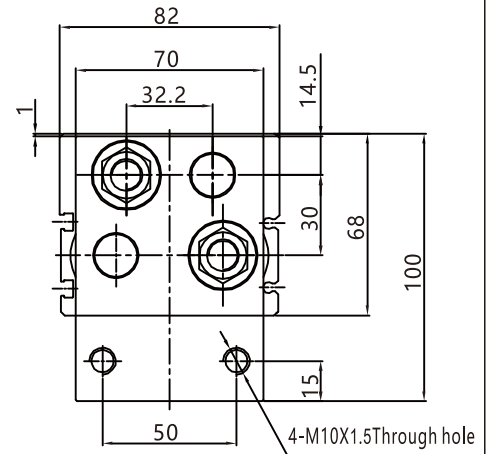
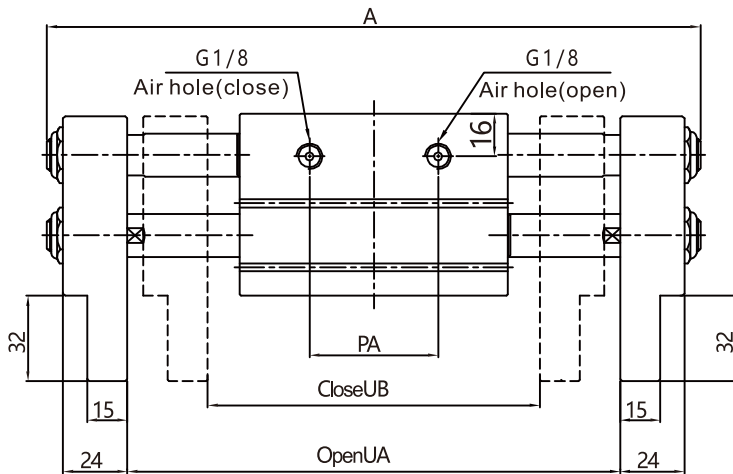

Sign/Bore	60	80	100	150
A	244	284	342	442
AB	100	120	158	208
KB	76	86	134	184
LB	50	60	108	158
PA	45	55	65	90
UA(Open)	184	224	282	382
UB (Close)	124	144	182	232

## Product type

1、Please select pneumatic finger according to the following steps

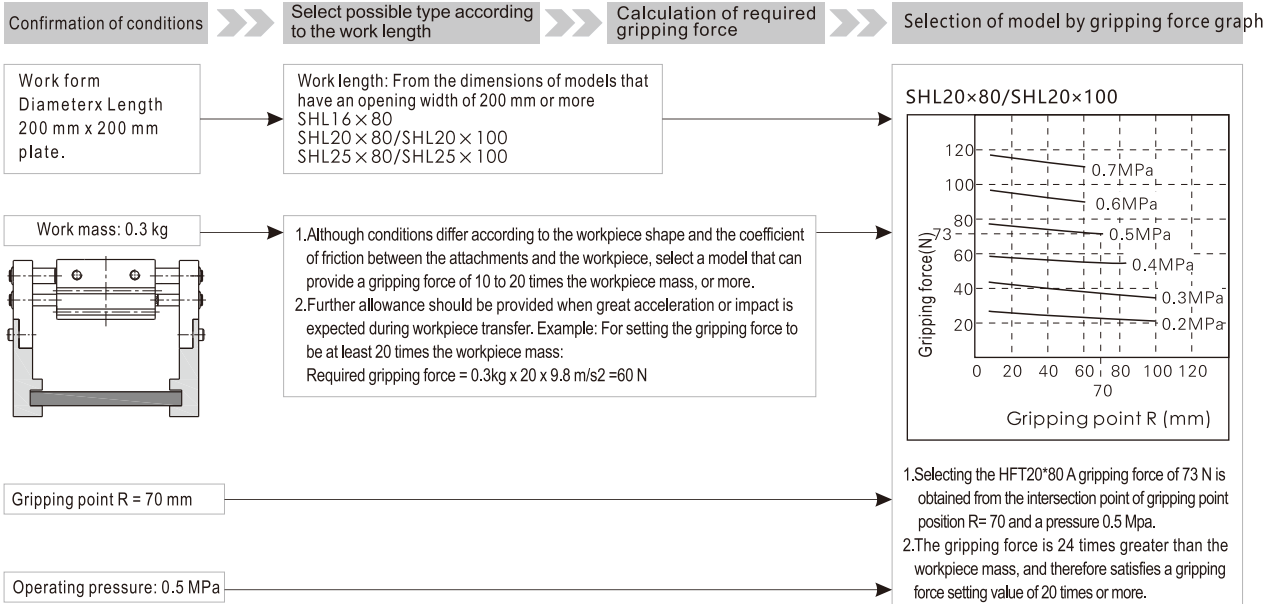

## 2、Gripping Point

- The workpiece gripping point distance should be within the gripping force ranges given for each pressure in the effective gripping force graphs below.
- If operated with the workpiece gripping point beyond the indicated ranges, the load that will be applied to the fingers or the guide will become excessively unbalanced. As a result, the fingers could become loosened and adversely affect the service life of the unit.

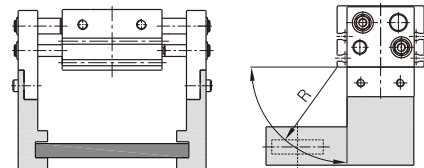

R: Gripping position (mm)

## 3、Effective Gripping Force

The gripping force shown in the tables represents the gripping force of one finger when all fingers and attachments are in contact with the work.

SHL16 × 30 / SHL16 × 40

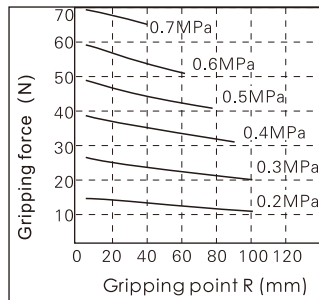

SHL16 × 60 / SHL16 × 80

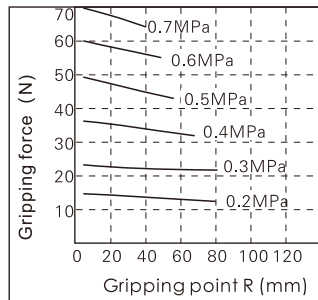

SHL20 × 40 / SHL20 × 60

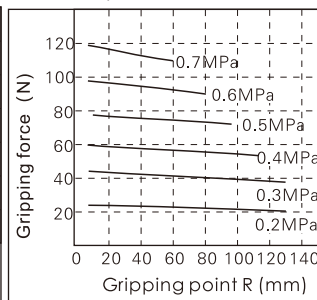

SHL20 × 80 / SHL20 × 100

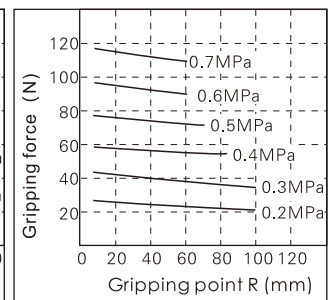

SHL25 × 40 / SHL25 × 60

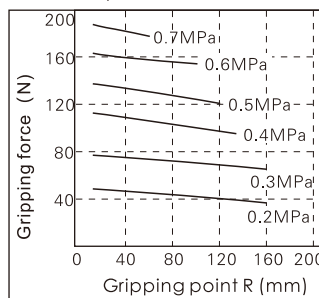

SHL25 × 80 / SHL25 × 100

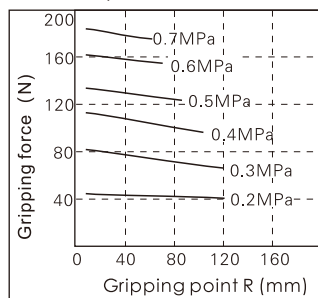

SHL32 × 60 / SHL32 × 80

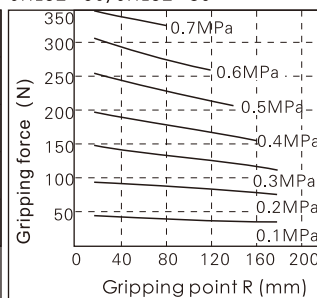

SHL32 × 100 / SHL32 × 150

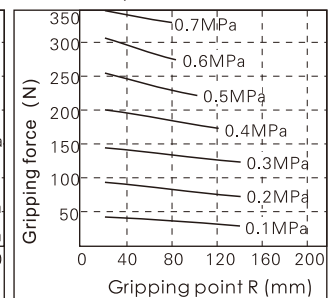

# SHL Wide Type Parallel Style Air Gripper



## Installation and application

1. Due to the abrupt changes, the circuit pressure is low, which will lead to the decrease of the gripping force and falling of the work-pieces. In order to avoid the harm to the human body and damage to the equipment, anti-dropping device must be equipped.
2. Don't use the air gripper under strong external force and impact force.
3. When install and fix the air gripper, avoid falling down, collision and damage.
4. When fixing the gripping jaw parts, don't twist the gripping jaw.
5. There are several kinds of installation method, and the locking torque of fastening screw must be within the prescribed torque range shown in the below chart. If the locking torque is too large, it will cause the dysfunctional. If the locking torque is too small, it will cause the position deviation and fall.

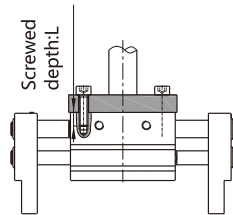

Axial mounted(thread hole)

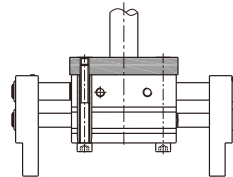

Axial mounted(through hole)

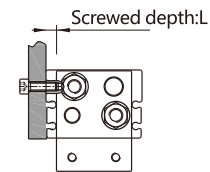

Beside mounted

Bore size	The bolts type	Max.locking moment (Nm)	Max.screwed depth (mm)
16	M5 × 0.8	4.3	10
20	M6 × 1.0	7.3	12
25	M8 × 1.25	17.7	16
32	M8 × 1.25	17.7	16

Bore size	The bolts type	Max.locking moment (Nm)
16	M5 × 0.8	4.3
20	M6 × 1.0	7.3
25	M8 × 1.25	17.7

Note: Not available for Ø32

Bore size	The bolts type	Max.locking moment (Nm)	Max.screwed depth (mm)
16	M5 × 0.8	2.8	7
20	M6 × 1.0	4.8	7
25	M8 × 1.25	12	7
32	M8 × 1.25	12	10

6. The installation method of the gripping jaw fittings:

When install the gripping jaw fittings, you have to pay particular attention that you can only hold the gripping jaw by using spanner, and then lock the screws with alien wrench. Never clamp the body directly and then lock the screws, otherwise the parts will be easily damaged.

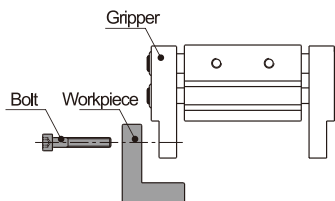

Bore size	The bolts type	Max.locking moment (Nm)
16	M5 × 0.8	2.8
20	M6 × 1.0	4.8
25	M8 × 1.25	12
32	M10 × 1.5	24

7. Confirm that there is no external forces exerted on the gripping jaw.

Transverse load acts on the gripping jaw, which will cause impact load and leads to the shaking and damage of gripping jaw. Equip with gaps so that the air gripper will not crash into work-pieces and accessories at the end of its trip.

- 7.1. The end of stroke under the open state of air gripper

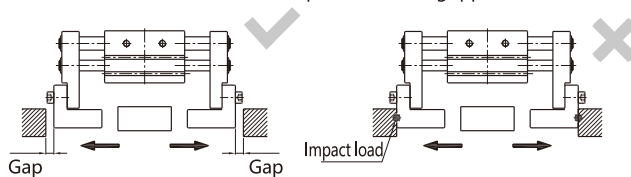

- 7.2. The end of stroke under the move state of air gripper

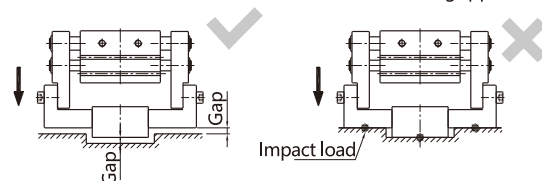

8. When the work-pieces are inserted, the center line should be coaxial, no offset, in case there are external force generated on gripping jaw.

When testing, it is specially required that the manual operation should be reduced, the pressure should be used to run it at a low speed, and guarantee the safety and no impact.



9. Please use the flow control valve to adjust the opening and closing speed of gripping jaw if too fast.
10. People can not enter the movement path of air gripper and articles can not be placed on the path too.
11. Before removing the air gripper, please confirm that it is out of working state, and then discharge of compressed air.