

EI Series Air Preparation Unit



How to Order?

Series No.	Type Code	Body Size	Combination QTY	Port Size	Drain Type	Pressure Gauge Code	Bracket Code	Scale Unit	Filter Precision	Thread Type
EI: Square gauge series	C: Filter+regulator+lubricator W: Filter+regulator F: Filter R: Regulator L: Lubricator	20: 2000 body 30: 3000 body 40: 4000 body 50: 5000 body	10: Two units (Regulator+Lubricator) 00: Others 2000 01: 1/8" 02: 1/4" 3000 02: 1/4" 03: 3/8"	4000 04: 1/2" 5000 06: 3/4" 10: 1"	Blank: Manual drain type C: Semi-auto drain D: Auto Drain type	Blank: With pressure gauge N: No pressure gauge	Blank: With bracket J: No bracket	1: Mpa 2: Bar *3: Psi (*Need special made)	Blank: 25 μm 5M: 5 μm	Blank: G P: PT T: NPT

Order Example:

EI series regulator, 2000 body size, 1/8 port size, with pressure gauge, Mpa pressure unit, G thread, ERP code is: EIR2000-01 1

Note: 1) 2000 series is optional for manual /auto drain type;

Standard 3000/4000/5000 series are optional for manual/semi-auto/semi-auto integrated drain type.

Air Preparation Unit Kits

EIF3000

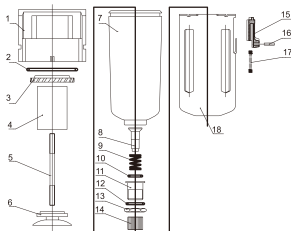

NO.	NAME	QTY	MATERIAL
18	Lock	1	ABS
17	Pin	1	ABS
16	Spring	1	Stainless steel
15	Metal bowl	1	Steel plate
14	Nut	1	HPb59-1
13	Hexagon Nut	1	HPb59-1
12	O-ring	1	NBR
11	Drain valve seat	1	HPb59-1
10	O-ring	1	NBR
9	Spring	1	Stainless steel
8	Drain valve core	1	HPb59-1
7	Water cup	1	HPb59-1
6	Drain board	1	ABS
5	Cross bolt	1	Carbon steel
4	Filter element	1	Cu
3	Blade	1	ABS
2	O-ring	1	NBR
1	Filter body	1	ADC12

EIR3000

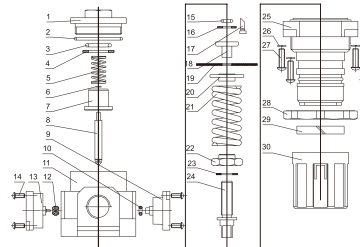

NO.	NAME	QTY	MATERIAL
30	Regulate handle	1	Reinforce nylon
29	Symbol ring	1	Reinforce nylon
28	plastic combination	1	POM
27	Cross screw	4	Carbon steel
26	Spring washer	4	Carbon steel
25	Regulator Body	1	Aluminum
24	Regulate bolt	1	Carbon steel
23	Washer	1	POM
22	Regulate Nut	1	Carbon steel
21	Spring	1	Stainless steel
20	Diaphragm-Pinjet	1	Carbon steel
19	Diaphragm	1	NBR
18	Diaphragm seal	1	Brass
17	Pipe	1	POM
16	Retainer ring	1	Steel plate
15	O-ring	1	NBR
14	Cross screw	4	Carbon steel
13	Plastic connection	1	POM
12	Seal	1	NBR
11	Regulator body	1	Aluminum
10	Seal	1	NBR
9	Connection	1	ADC12
8	Spool	1	Brass+NBR
7	Valve core	1	Brass
6	Retainer ring	1	Steel plate
5	Spring	1	Stainless steel
4	Retainer ring	1	Steel plate
3	O-ring	1	NBR
2	O-ring	1	NBR
1	Regulator seat	1	ZZnAl-1

EIL3000

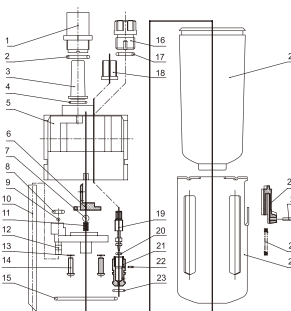

NO.	NAME	QTY	MATERIAL
28	Oil cup	1	Polycarbonate
27	Lock	1	ABS
26	Pin	1	ABS
25	Spring	1	Stainless steel
24	Metal bowl	1	Steel plate
23	O-ring	1	NBR
22	Pin	1	Q235
21	Oil regulate seal	1	HPb59-1
20	O-ring	1	NBR
19	Oil regulate needle	1	HPb59-1
18	Oil regulate porrier	1	ABS
17	O-ring	1	NBR
16	Plug	1	ABS
15	O-ring	1	NBR
14	Cross screw	2	Q235
13	Spring washer	2	65Mn
12	One way valve plate	1	POM
11	Spring	1	Stainless steel
10	Pipe	1	PUI tube
9	Steel ball	1	Q235
8	O-ring	1	NBR
7	Steel ball	1	Q235
6	Reed	1	Polycarbonate
5	Lubricator body	1	ADC12
4	O-ring	1	NBR
3	Oil drop tube	1	Polycarbonate
2	O-ring	1	NBR
1	Oil window	1	Polycarbonate

EIW3000

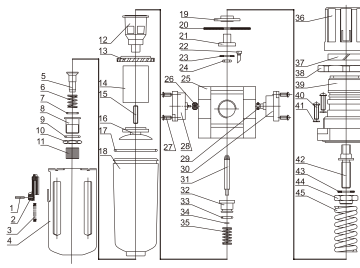

NO.	NAME	QTY	MATERIAL
45	Spring	1	Carbon steel
44	Regulate nut	1	Carbon steel
43	Washer	1	POM
42	Regulate bolt	1	Carbon steel
41	Spring washer	4	Carbon steel
40	Cross screw	4	Carbon steel
39	Valve cover	1	Reinforce nylon
38	Nut	1	Reinforce nylon
37	Symbol ring	1	Reinforce nylon
36	Regulate handle	1	Reinforce nylon
35	Spring	1	Stainless steel
34	Retainer ring	1	Steel plate
33	O-ring	1	NBR
32	Valve core	1	Brass
31	Spool	1	HPb59-1+NBR
30	connection	1	ADC12
29	Seal	1	NBR
28	Plastic connection	1	POM
27	Cross screw	4	Carbon steel
26	Seal	1	NBR
25	Regulator Body	1	Aluminum
24	O-ring	1	NBR
23	Retainer ring	1	Carbon steel
22	Pipe	1	POM
21	Diaphragm seal	1	Brass
20	Diaphragm	1	NBR
19	Diaphragm Pinjet	1	Carbon steel
18	Water cup	1	Polycarbonate
17	O-ring	1	NBR
16	Drain board	1	ABS
15	Bolt	1	Carbon steel
14	Filter element	1	ABS
13	Whirring blade	1	ABS
12	Overbow valve seat	1	ZZnAl-1
11	Boil guard	1	Carbon steel
10	Spring	1	Stainless steel
9	Lock	1	ABS
8	Pin	1	ABS
7	Nut	1	Brass
6	Hex Nut	1	Brass
5	O-ring	1	NBR
4	Drain valve	1	Brass
3	O-ring	1	NBR
2	Spring	1	Stainless steel
1	Valve core	1	Brass

EIL Series Air Preparation Unit



EIL Lubricator

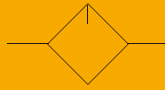

Specifications

Model	EIL2000	EIL3000	EIL4000	EIL5000
Proof pressure(MPa)	1.5			
Working Pressure Range(MPa)	0.05~1.0			
Working temperature(°C)	-5~60			
Recommended oil	Turbine No.1 Oil ISOVG32			
Bowl material	Polycarbonate			
Bowl guard	None	Available		
Entrance pressure(MPa)	0.15~1.0			

Model	Specifications			
	* Minimal flow of oil drop (L/min)	* Rated flow (L/min)	* Port size(G)	Bowl capacity (cm ³)
EIL2000-01	15	1300	1/8	25
EIL2000-02		1345	1/4	
EIL3000-02	30	2310	1/4	50
EIL3000-03	40	2375	3/8	
EIL4000-04	50	5532	1/2	130
EIL5000-06	190	7700	3/4	
EIL5000-10		8000	1	130

- * The above information is based on 6.3 Bar supply pressure, the flow of oil drop is 2~3 drops/ min, the temperature of Turbine No.1 oil is 20°C
- * The above information is based on 6.3 Bar supply pressure and 1.0 Bar step down
- * NPT,PT port size is optional

Main Dimension

EIL2000

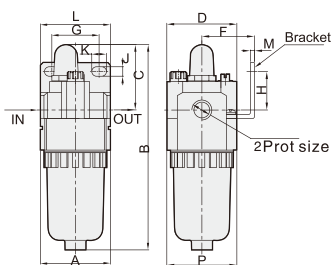

EIL3000-EIL4000

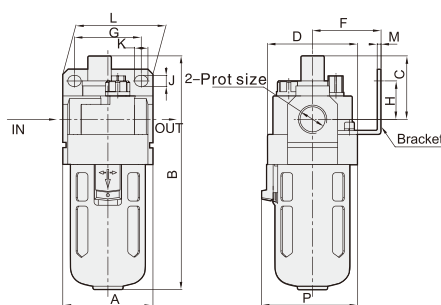

EIL5000

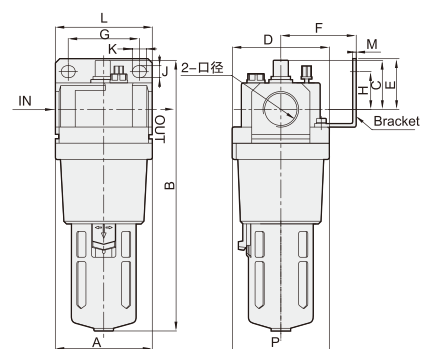

Model	Port Size (G)	A	B	C	D	F	G	H	J	K	L	M	P
EIL2000	1/8"-1/4"	40	115	37.5	40	31	19	14	17	6.8	40	2	40
EIL3000	1/4"-3/8"	53	141	39	53	41	40	23	6.5	8	53	2	56
EIL4000	3/8"-1/2"	70	175	40	70	53	54	26	8.5	10.5	70	2	73
EIL5000	3/4"-1"	90	254	45.5	90	67	66	35	11	13	90	3	90