

AEC/BEC

F.R.L

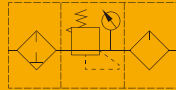

How to Order?

Series No.	Type Code	Body Size	Pressure Gauge Code	Bracket Code	Scale Unit	Thread Type
AE: Small body size without bowl guard BE: Larger body size with bowl guard	C: Filter+regulator+lubricator	2000: 1/4" 3000: 3/8" 4000: 1/2"	Blank: With pressure gauge N: No pressure gauge	Blank: With bracket J: No bracket	4: Mpa/Psi(Default) 5: Bar/Psi	Blank: G P: PT T: NPT

Order Example:

AE series three units, 2000 body size, with gauge, with bracket, Mpa/Psi pressure scale unit, PT thread, ERP code is: AEC2000-4-P

Main Dimension

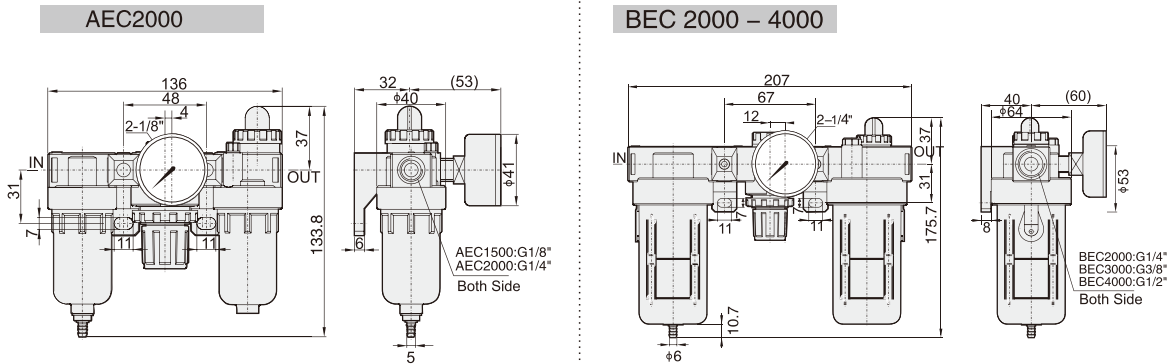

Specifications

Model	AEC2000	BEC2000	BEC3000	BEC4000	
Working medium	Air				
Port size	G1/4	G1/4	G3/8	G1/2	
Filter precision	40 μm (5, 40 μm is optional)				
Adjusting pressure range (MPa)	0.15-0.85				
Max. adjusting pressure (MPa)	1.0				
Guaranteed pressure (MPa)	1.5				
Working temperature(°C)	5-60				
Filter bowl capacity (CC)	15	60		60	
Lubricator bowl capacity (CC)	25	90		90	
Recommend oil	ISO VG32 or equivalent oil				
Weight (g)	700	900		900	
Components	Filter	AEF2000	BEF2000	BEF3000	BEF4000
	Regulator	AER2000	BER2000	BER3000	BER4000
	Lubricator	AEL2000	BEL2000	BEL3000	BEL4000