

EMCJ

全不锈钢角座阀



EMCJ全不锈钢角座阀

产品特性

- * 常闭全不锈钢角座阀, 阀体材质: 不锈钢304, 不锈钢316
- * 有多种密封件可以选择以适应不同的介质
- * 接管口径从3/8"到2"

订货举例

系列代码	接管口径	执行器缸径	作用形式	阀体材质	牙型代码	
EMCJ: 全不锈钢系列角座阀	10: 3/8" 15: 1/2" 20: 3/4" 25: 1"	32: 1-1/4" 40: 1-1/2" 50: 2"	40: Φ 40mm 50: Φ 50mm 63: Φ 63mm 80: Φ 80mm 100: Φ 100mm	空白: 单作用常闭 D: 双作用自由状态 DC: 双作用常闭型 备注: 标准为无水锤型, 有水锤型可非标定制。	S1: SUS316 S2: SUS304	空白: G P: PT T: NPT

订货举例: 全不锈钢系列角座阀, 接管口径为3/8, 执行器缸径为40mm, 单作用常闭型, 阀体材质SUS316, G牙, 其ERP编码为: EMCJ-1040S1

外形尺寸图

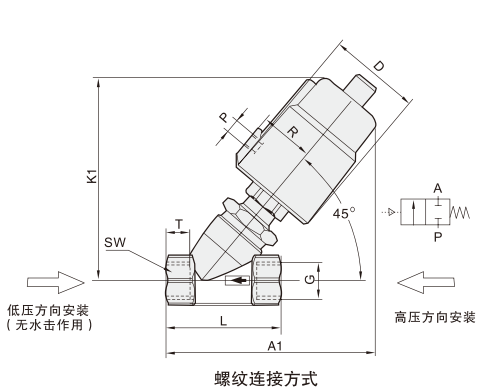

规格	执行器 (mm)	D (mm)	R (mm)	P	螺纹					
					G	K1 (mm)	A1 (mm)	L (mm)	T (mm)	SW (mm)
DN10	40	50.5	27	G1/8"	G3/8"	115	120	68	12	22
	50	62	34	G1/8"	G3/8"	126	133	68	12	22
DN15	40	50.5	27	G1/8"	G1/2"	115	120	68	15	25
	50	62	34	G1/8"	G1/2"	126	133	68	15	25
DN20	50	62	34	G1/8"	G3/4"	131	137	75	16	31
	50	62	34	G1/8"	G1"	140	149	100	17	39
DN25	63	77	41.5	G1/8"	G1"	165	174	100	17	39
	63	77	41.5	G1/8"	G1-1/4"	175	188	116	21	50
DN40	63	77	41.5	G1/8"	G1-1/2"	178	190	116	21	56
	63	77	41.5	G1/8"	G2"	184	203	138	22	68

规格

型号	EMCJ10-50	型号	EMCJ10-50
接口尺寸	DN10-DN50	介质温度 (°C)	PTFE: -10 ~ +180
螺纹	G3/8"-G2"	环境温度 (°C)	-10 ~ +60
阀体材质	CF8M	粘度 (mm ² /s)	Max600
执行器材质	CF8	安装	任意位置
阀芯密封	PTFE	控制介质	空气/中性气体
阀杆密封	PTFE/FKM	控制压力范围 (Bar)	3-10
适用介质	水, 中性气体或液体, 酒精, 油, 有机溶剂, 水蒸气, 弱酸或弱碱溶液		

流向：阀座上方 单作用常闭/常开

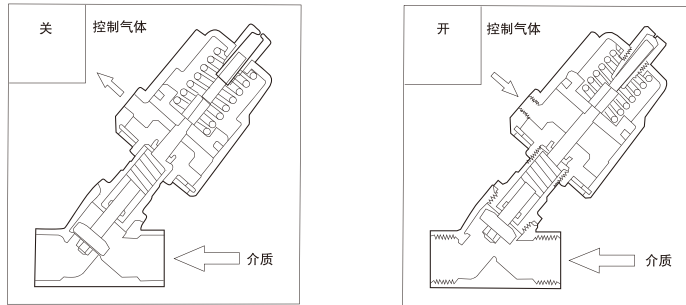

规格

规格	接管口径	流量通径 (mm)	执行器 (mm)	Kv值	工作压力 (Bar)	常闭		常开		订货号	
						允许压差范围 (Bar)	控制压力范围 (Bar)	允许压差范围 (Bar)	控制压力范围 (Bar)	单动常闭 N.C.	单动常开 N.O.
DN10	G3/8"	13	40	4.7	16	0-16	≥4	-	-	EMCJ10-40	-
	G3/8"	13	50	4.7		0-16	≥3	0-16	3	EMCJ10-50	EMCJ10-50H
DN15	G1/2"	13	40	4.7		0-16	≥4	-	-	EMCJ15-40	-
	G1/2"	13	50	4.7		0-16	≥3	0-16	3	EMCJ15-50	EMCJ15-50H
DN20	G3/4"	18	50	9.5		0-16	3-4	0-16	3	EMCJ20-50	EMCJ20-50H
DN25	G1"	24	50	18.1		0-16	3-5.5	-	-	EMCJ25-50	-
	G1"	24	63	18.1		0-16	3-3.5	0-16	3.5	EMCJ25-63	EMCJ25-63H
DN32	G1-1/4"	31	63	23.1		0-16	3-5	0-14	3.9	EMCJ32-63	EMCJ32-63H
DN40	G1-1/2"	35	63	32.9		0-16	3-6	0-11	3.9	EMCJ40-63	EMCJ40-63H
DN50	G2"	45	63	52.8		0-10	3-6.5	0-6	3.9	EMCJ50-63	EMCJ50-63H
	G2"	45	80	52.8		0-16	3-6.6	0-12	4.5	EMCJ50-80	EMCJ50-80H

流量特性

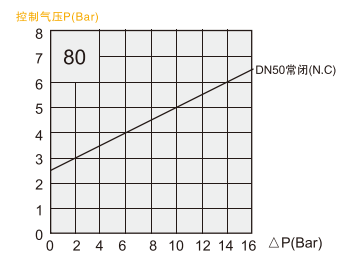
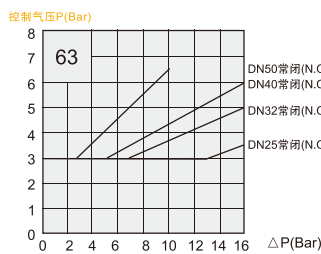
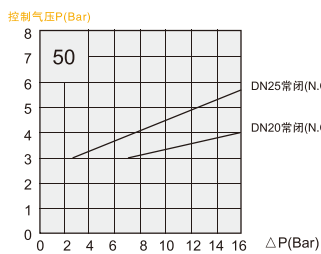

流向：阀座上方 双作用常闭/常开

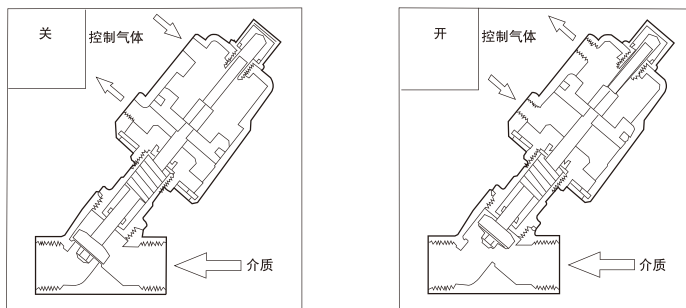

规格

规格	接口	流量 口径	执行器 (mm)	Kv 值	工作压力 180°C (Bar)	允许压差 (Bar)	控制压力		订货号	
							双作用常闭 (N.C) (Bar)	双作用自由状态 (Bar)	双作用常闭 (N.C)	双作用自由状态
DN10	G3/8"	13	40	4.7	16	0-16	≥4	0-2	EMCJ10-40DC	EMCJ10-40D
DN10	G3/8"	13	50	4.7		0-16	≥3	0-1	EMCJ10-50DC	EMCJ10-50D
DN15	G1/2"	13	40	4.7		0-16	≥4	0-2	EMCJ15-40DC	EMCJ15-40D
DN15	G1/2"	13	50	4.7		0-16	≥3	0-1	EMCJ15-50DC	EMCJ15-50D
DN20	G3/4"	18	50	9.5		0-16	3-4	0-2	EMCJ20-50DC	EMCJ20-50D
DN25	G1"	24	50	18.1		0-16	3-5.5	0-3.5	EMCJ25-50DC	EMCJ25-50D
DN25	G1"	24	63	18.1		0-16	3-3.5	0-2	EMCJ25-63DC	EMCJ25-63D
DN32	G1- 1/4"	31	63	23.1		0-16	3-5	0-4	EMCJ32-63DC	EMCJ32-63D
DN40	G1- 1/2"	35	63	32.9		0-16	3-6	0-5	EMCJ40-63DC	EMCJ40-63D
DN50	G2"	45	63	52.8		0-10	3-6.5	0-5	EMCJ50-63DC	EMCJ50-63D
DN50	G2"	45	80	52.8		0-16	3-6.6	0-5	EMCJ50-80DC	EMCJ50-80D

流量特性

控制气压P(Bar)

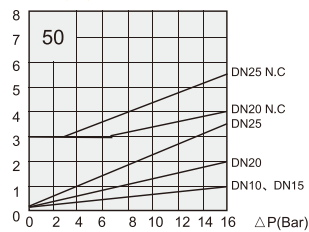

控制气压P(Bar)

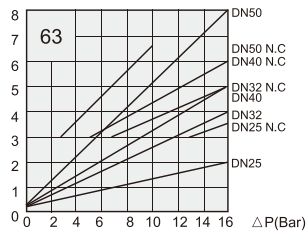

控制气压P(Bar)

