

SZP

Mark-free Pad



Product Features

- Pad which reduces the number of adsorption marks left on workpieces by the rubber;
- The pad is made from mark-free NBR, and the NBR is then specially treated to minimize the transfer of rubber constituents to workpieces.

How to Order?

Series No.	Pad Diameter	Pad Type	Pad material	Lock ring
SZP: SZP Series	06: Ø6 10: Ø10 16: Ø16 25: Ø25 40: Ø40	Code U	LH: Mark-free	Blank: with lock ring X19: without lock ring
		Pad type Flat type		

Order Example:

SZP series mark-free vacuum pad, pad diameter is ϕ 16, plat type, mark-free, without lock ring
Order code is SZP16ULH-X19

Main Dimensions

SZP06ULH

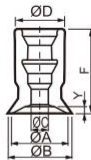

SZP10ULH-40ULH

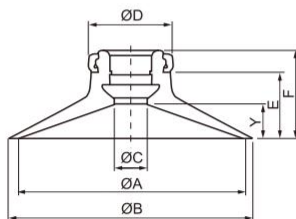

Model	ØA	ØB	ØC	ØD	E	F	Y
SZP06ULH	6	7	2.5	7	-	12	0.8
SZP10ULH	10	12	5	13	7.7	12	3
SZP16ULH	16	18	5	13	8.2	12.5	3.5
SZP25ULH	25	28	5	15	9.5	14	4
SZP40ULH	40	43	7	18	13.7	18.5	6.5

SZP Series Mark-free Pad



SZP3E Series Mark-free Pad



How to order?

Series No.	Pad Diameter	Pad Type	Pad material	Plate
SZP3E:	50: Ø50		LH: Mark-free	Blank: without plate
SZP3E Series	63: Ø63			P: with plate
	80: Ø80	Code		
	100: Ø100	UM	Pad type	
	125: Ø125		Flat type with ribs	

Order Example:

SZP3E series mark-free vacuum pad, pad diameter is ϕ 50, plat type with ribs, mark-free, with plate.
Order code is SZP3E-50UMLH-P

Main Dimensions

SZP3E-50UMLH-□

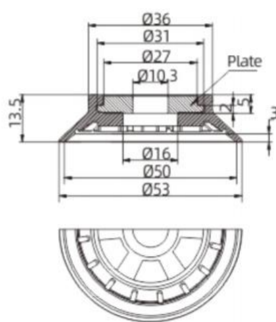

SZP3E-63UMLH-□

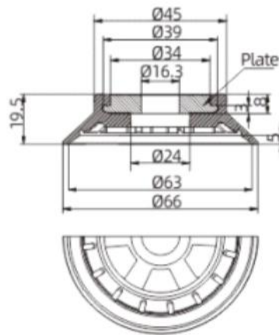

SZP3E-83UMLH-□

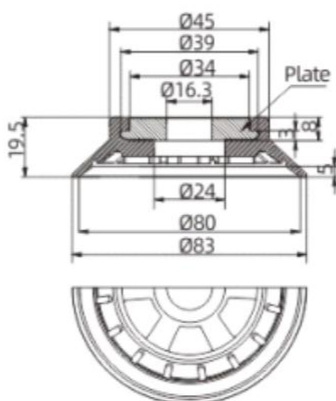

SZP3E-100UMLH-□

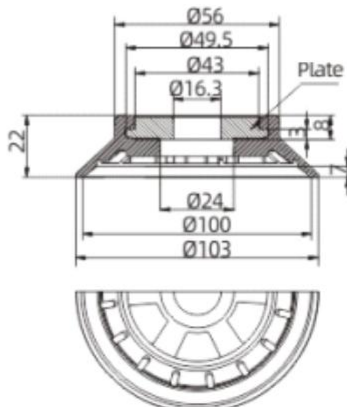

SZP3E-125UMLH-□

