

SQK

Rotary Clamp Cylinder

SQK: Standard double-action type, with magnetism



Specifications



Bore(mm)	16	20	25	32	40
Acting Type	Double Acting				
Working medium	Clean Air(40 μm filtration)				
Working pressure (MPa)	0.15~1.0(MPa)				
Guaranteed pressure (MPa)	1.5(MPa)				
Working temperature (°C)	-20~70(No freezing)				
Piston Speed (mm/s)	50~200				
Rotation angle	90° ± 2°				
Rotation Direction	Left rotation or right rotation				
Rotation Stroke(mm)	7.5	9.5		15	
Clamping stroke (mm)	10 20 30		10 20 30 50		
Stroke Tolerance	+1.0 0				
Cushion Type	Rubber cushion				
Port Size	M5x0.8			G1/8	
Non-rotating accuracy (clamping part)	± 1.2°			± 0.9°	

How to Order?

Series No	Rotation Direction	Bore X Stroke	Magnet.No	Type No	Mounting Type	Thread Type
SQK	R:Right Rotation L:Left Rotation	16 10 20 20 25 30 32 50 40	S: With magnet	Blank: Basic Type(with arm) J: No arm	Blank: No mounting	Blank: G P : PT T : NPT

Order Example:

SQK series basic type cylinder, bore 25mm, stroke20mm, right rotation, G thread, with arm, no mounting, ERP code is: SQKR25 × 20-S

Optional Accessories

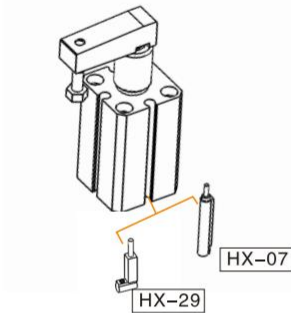

Note:Short stroke please use HX-29 series due to limited space.

Definition of Rotation Direction and Rotation Angle

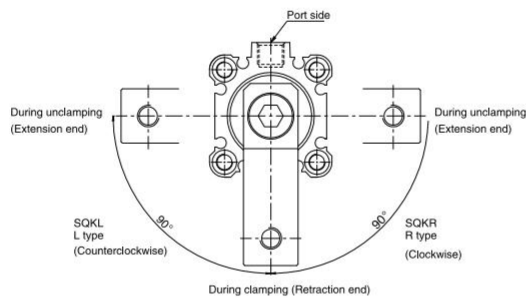

Stroke

	Bore(mm)	Clamping Stroke(mm)	Max.Clamping Stroke(mm)
Double acting	16、20、25	10 20 30	30
	32、40	10 20 30 50	50

SQK Series Rotary Clamp Cylinder



Internal Structure

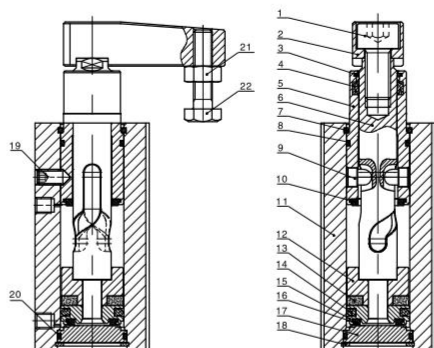

No.	Part Name	Material	No.	Part Name	Material
1	Hex Socket Cap Screw	Carbon steel	12	Magnet Base	Aluminium alloy
2	Clamping Arm	Steel	13	Integral Magnet	NdFeB/Plastic
3	Dust Scraping Ring	Free Machining Steel	14	Piston Seal	NBR
4	Piston Rod Seal	NBR	15	Piston	Aluminium alloy
5	Head Cover	Aluminium alloy	16	Anti-collision Gasket	PTEE
6	Piston Rod	Special material	17	Rear Cover	Aluminium alloy
7	Check Ring	Spring Steel/Stainless Steel	18	Check Ring for C Type Hole	Spring Steel
8	O-ring	NBR	19	Hex Socket Tighten Screw	Carbon steel
9	Rolling Stopper Pin	Special material	20	O-ring	NBR
10	Anti-collision Gasket	TPU	21	Hex Nut	Carbon steel
11	Barrel	Aluminium alloy	22	Hex bolt	Stainless Steel

Main Dimension

SQK $\Phi 16$

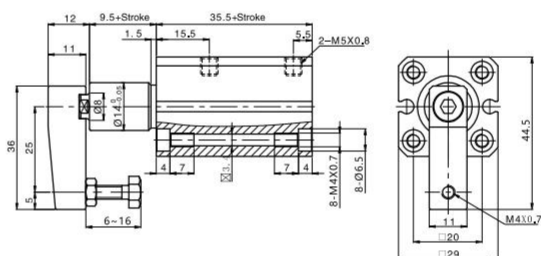

SQK $\Phi 20$, $\Phi 25$

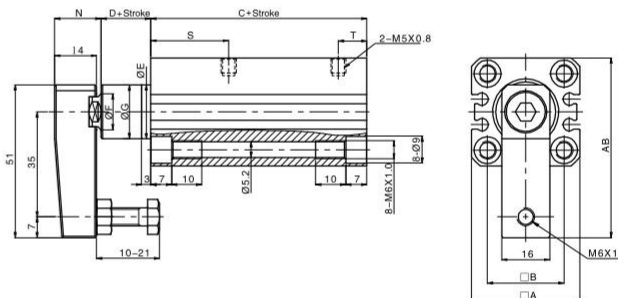

Bore/Sign	A	AB	B	C	D	E	F	G	N	S	T
20	36	60	25.5	62	6.5	18 _{±0.05}	12	17.9	15.5	26	9.5
25	40	62	28	63	6.5	23 _{±0.05}	12	22.5	15.5	27.5	10

SQK $\Phi 32$, $\Phi 40$

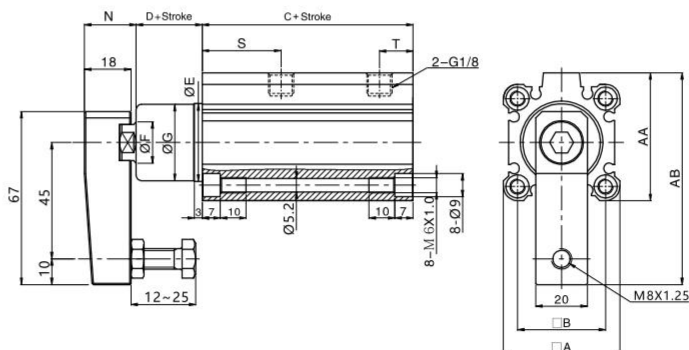

No arm



Bore/Sign	A	AA	AB	B	C	D	E	F	G	N	S	T
32	45	49.5	82	34	71.5	15.5	30 _{±0.05}	16	29.5	20	30.5	13
40	52	51	86	40	65	23	30 _{±0.05}	16	29.5	20	27.5	8

4
SQK

Installation and Use

1. Dirty substances in the pipe must be eliminated before cylinder is connected with pipeline to prevent the entrance of impurities into the cylinder.
2. The medium used by cylinder shall be filtered to $40\ \mu\text{m}$ or below.
3. Anti-freezing measure shall be adopted under low temperature environment to prevent moisture freezing.
4. If the cylinder is dismantled and stored for a long time, please conduct anti-rust treatment to the surface. Anti-dust jam cap shall be added in air inlet and outlet ports.
5. To insure the life-span of cylinder and jig, please use flow control valve to control the speed of cylinder.
6. The method of installation are mounted by flange on top or bottom.

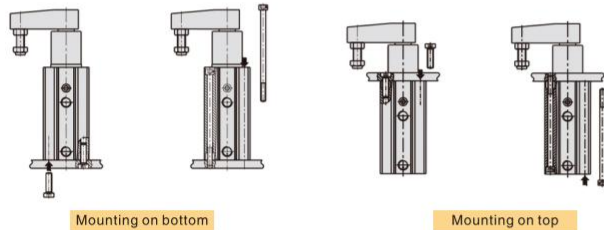

7. Please clean the piston rod and dust scraping ring to protect the cylinder.
8. Magnetic switch of SQK is same as SQ series cylinder.
9. Please install the cylinder as below diagram.

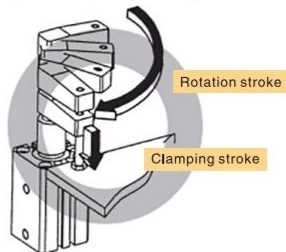

Model Selection

1. The cylinder comes with a standard swing arm. When modifying or making your own swing arm, please choose the appropriate cylinder according to the following principles.
2. Allowable bending torque requirements: Please use the pendulum length and operating pressure within the range shown in the following figure (Chart 1).

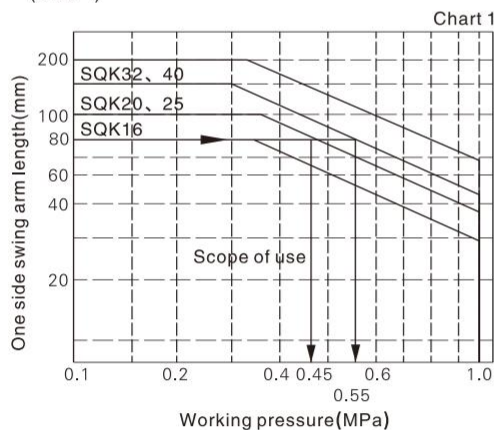

Example: When the length of the swing arm is 80mm, SQK20 and 25 should be used at a pressure below 0.45MPa, SQK32 and 40 should be used at a pressure below 0.55MPa.

10. The installation method as the diagram below is wrong, and will injure the cylinder and shorten the cylinder life.

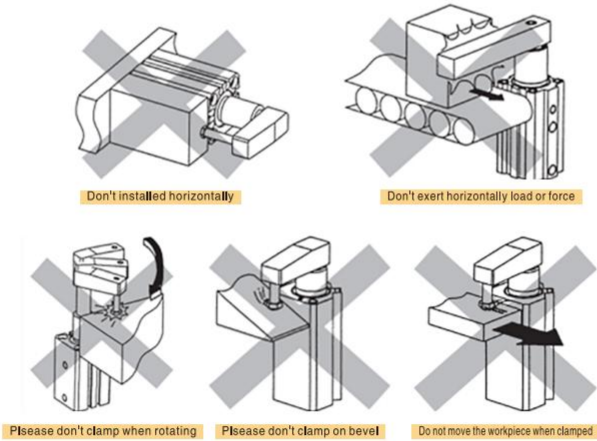

11. Please follow the diagram below on right side to assemble/disassemble the rocker by spanner and allen wrench, don't hold the body to assemble/diassemble rocker, or will damage the cylinder.

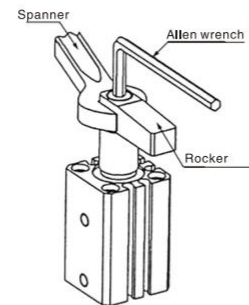

3. Allowable Inertia Torque :

If the cylinder runs too fast, it will cause damage to the internal parts; According to the inertia torque of the swing arm, the gas running speed should be used in the range shown in the figure below (Figure 2).

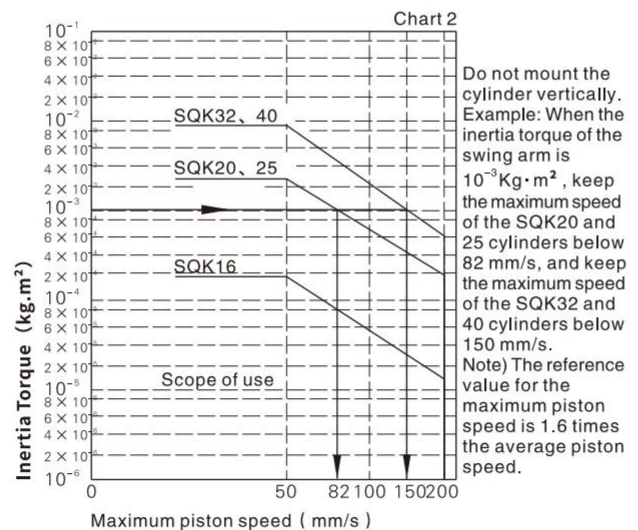

Do not mount the cylinder vertically. Example: When the inertia torque of the swing arm is $10^{-3}\text{Kg}\cdot\text{m}^2$, keep the maximum speed of the SQK20 and 25 cylinders below 82 mm/s, and keep the maximum speed of the SQK32 and 40 cylinders below 150 mm/s. Note) The reference value for the maximum piston speed is 1.6 times the average piston speed.

SQK Series Rotary Clamp Cylinder



Model Selection

4. The inertia torque requirement of the cylinder's self-swinging arm around the cylinder's rotational axis (Chart 3).

(Chart 3)

Model	Inertia Torque(Kg · m ²)
SQK16	1.053X10 ⁻⁵
SQK20/25	5.257X10 ⁻⁵
SQK32/40	1.653X10 ⁻⁴

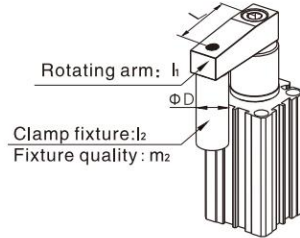

5. Calculation examples:

5.1、 Determine the rotating arm moment of inertia (I_1):After selecting the cylinder bore, it can be found by the torque of inertia requirements table (chart 3)

5.2、 Determine the moment of inertia of the clamping fixture (I_2) : according to the shape of the body combined with Article 6, "commonly used object moment of inertia calculation formula", choose the appropriate formula to calculate.

The fixture on the right is a cylinder, and the moment of inertia is calculated as follows: $I_2=(m_2 \cdot D^2) / 8+m_2 \cdot L^2$

When SQK32 cylinder is selected: $L=0.045m$ (external dimension); Suppose $D=0.04m$ $m_2=0.4kg$

Check the table: $I_2=1.653 \times 10^{-4} (Kg \cdot m^2)$

Through calculation, we can get: $I_2=(m_2 \cdot D^2) / 8+m_2 \cdot L^2=(0.4 \cdot 0.04^2) / 8+0.4 \cdot 0.045^2=8.9 \times 10^{-4} (Kg \cdot m^2)$

Actual moment of inertia: $I=I_1+I_2=10.553 \times 10^{-4}=1.0553 \times 10^{-3} (Kg \cdot m^2)$

Check Chart 2 to find that the maximum speed of the cylinder cannot be exceeded 150mm/s;

Refer to Figure 1 to see that the cylinder can be used at 1MPa pressure.

Average piston speed = Maximum piston speed / 1.6=94(mm/s)

6. Commonly used object moment of inertia calculation formula:

Graphical Representation	Formula for calculating the moment of inertia	Graphical Representation	Formula for calculating the moment of inertia
<p>1. Thin rod Rotation axis position: Vertical and pass through one end of the thin rod</p>	$I = \frac{m_1 a_1^2 + m_2 a_2^2}{3}$	<p>4. Rectangular sheet (cube) Position of the axis of rotation: Parallel to side b and through the center of gravity of the rectangle</p>	$I = \frac{m a^2}{12}$
<p>2. Thin rod Rotation axis position: Vertical and pass the center of gravity of the thin rod</p>	$I = \frac{m a^2}{12}$	<p>5. Rectangular sheet (cube) Position of the axis of rotation: Vertical and pass one end of the rectangular plate</p>	$I = m_1 \times \frac{4a_1^2 + b^2}{12} + m_2 \times \frac{4a_2^2 + b^2}{12}$
<p>3. When the front end of the handle is loaded</p>	$I = m_1 \times \frac{a_1^2}{3} + m_1 \times a_2^2 + K$ $K = m_2 \times \frac{2r^2}{5}$	<p>6. Rectangular sheet (cube) Position of the axis of rotation: Vertical and pass the center of gravity of the rectangular plate</p>	$I = \frac{m a^2 + m b^2}{12}$