

KE18



Features

- The external damping spring has very good compensation for different heights when conveying workpieces.
- Large range of connection threads and lifting heights enables use for a wide variety of applications and suction pads.
- Spring damping and soft contact with sensitive workpieces.
- Abrasion resistant guide rod, longer life.

How to Order?

Series No.	Suction Cup Connection	Lifting Heights	— □ —	Guide Bush Male Thread
KE: External damping spring	18: G1/8	10: 10mm stroke 20: 20mm stroke 30: 30mm stroke 50: 50mm stroke	Blank: standard V: female thread	A16: M16X1 A18: M18X1

Order Example: KE External Damping Spring Plungers, suction cup connection G1/8, lifting heights stroke 10mm, standard thread, guide bush male thread M16X1. Order code is: KE1810-A16

Main Dimension

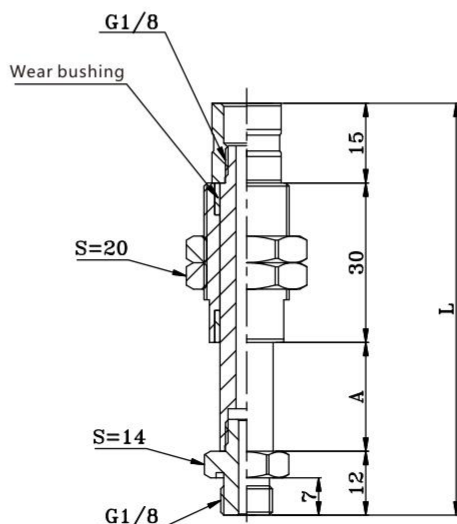

KE18 10-□-A16

① ②

①Lifting Heights	②Blank Default /V	A	L
10	Conventional fittings/internal thread fittings	20.5	77.5
20		35.5	92.5
30		50.5	107.5
50		70.5	127.5