

FB

Vacuum Filter



Product Features

- Filter the dust and other impurities sucked in from the air intake.
- You could check the element inside through transparent bowl.
- Filter element can be replaced.
- Reduce the risk of interruption or stoppage of vacuum pump and vacuum ejectors.
- Different nominal flow specifications are available.
- Press and rotate assembly for easy disassembly and installation.

How to Order?

Series No.	Thread Size	Filter Material
FB: FB Series	10: G3/8 female thread 15: G1/2 female thread 20: G3/4 female thread	Blank: PE (Nominal filtration rating 10 μm)

Order Example: FB Series Vacuum Filter, G3/8 female thread, PE filter material. Order code is: FB-10

Performance Overview

- Suit for vacuum systems with moderate and light pollution levels.
- It can be used as pre-filtration, filter different degrees of dust effectively.

Main Dimension

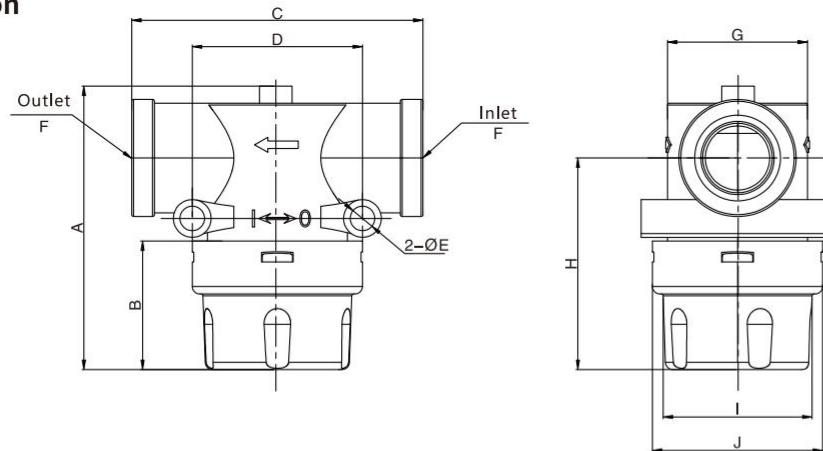

Model	A	B	C	D	E	F	G	H	I	J
FB-10	75	34	77	45	6	G3/8	51	56	39	45
FB-15	141	91	97.5	60	6	G1/2	71	117	57.5	69.5
FB-20	141	91	97.5	60	6	G3/4	71	117	57.5	69.5

Performance Parameters

Model No.	Pressure Range (kPa)	Material	Temperature Range (°C)	Filter Precision (μm)	Nominal Flow (NL/min)	Internal Vacuum Capacity (cm ²)	Filter Area (cm ²)	Weight (g)
FB-10	-100~0	PA-noumenon	-20~80	10	150	45	0.003	70
FB-15		PC-filter bowl			900	195	0.010	168
FB-20		PE-filter element			900	205	0.010	170

Filter Element Specification

	FB10-LX	FB15-LX	FB20-LX
Weight(g)	7	26	26
Filter Area(m ²)	0.003	0.010	0.010
Nominal Filtration Rating(μm)	10	10	10