

Stroke

Bore (mm)	Standard Stroke (mm)	Max. Stroke (mm)
32	25 50 75 80 100 125 150 160 175 200 250 300 350 400 450 500	1900
40	25 50 75 80 100 125 150 160 175 200 250 300 350 400 450 500 600 700 800	1900
50-160	25 50 75 80 100 125 150 160 175 200 250 300 350 400 450 500 600 700 800 900 1000	1900

Internal Structure

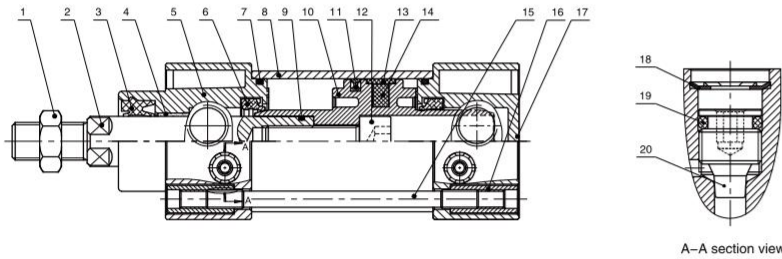

NO.	Part Name	Material
1	Nut	Carbon steel
2	Piston rod	S45C hard chrome carbon steel
3	Piston rod seal	TPU
4	Self lubricating bearing	Bronze powder
5	Head cover	Aluminum alloy
6	Cushion seal	NBR
7	O-ring	NBR
8	Barrel	Aluminum alloy
9	O-ring	NBR
10	Piston	Aluminum alloy
11	Piston seal	NBR
12	Screw	Carbon steel
13	Wear ring	PTFE
14	Magnet	Plastic
15	Tie rod	Carbon steel
16	Tie rod nut	Carbon steel
17	Rear cover	Aluminum alloy
18	Retainer ring	Spring steel
19	O-ring	NBR
20	Nut	Brass

Main Dimension

TBC $\Phi 32-\Phi 160$

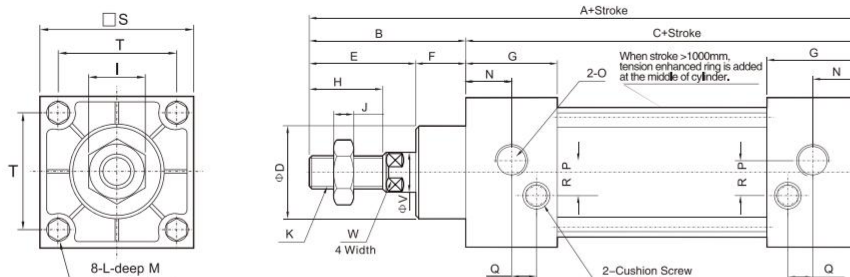

Bore/Sign	A	B	C	D	E	F	G	H	I	J	K	L
32	140	47	93	26	32	15	27.5	22	17	6	M10X1.25	M6X1
40	142	49	93	32	34	15	27.5	24	17	7	M12X1.25	M6X1
50	150	57	93	38	42	15	27.5	32	23	8	M16X1.5	M6X1
63	153	57	96	38	42	15	27.5	32	23	8	M16X1.5	M8X1.25
80	182	75	107	46	54	21	33	40	26	10	M20X1.5	M10X1.5
100	188	75	113	46	54	21	33	40	26	10	M20X1.5	M10X1.5
125	218	88	130	52	68	20	38	54	41	13.5	M27X2.0	M12X1.75
160	254	113	141	62	88	25	38	72	55	18	M36X2.0	M16X2.0

Bore/Sign	M	N	O	P	Q	R	S	T	V	W
32	13	14	1/8"	3.5	7	6.5	45	33	12	10
40	13	13.5	1/4"	5	5.5	8.5	50	37	16	14
50	13	14.5	1/4"	8.5	3	11	62	47	20	17
63	13	15	3/8"	7	5	9.5	75	56	20	17
80	15.5	16.5	3/8"	7	8	10	94	70	25	22
100	15.5	16.5	1/2"	7.5	8	13	112	84	25	22
125	19	19	1/2"	15	5	15	137.5	104	32	27
160	19.5	19	3/4"	15	6	15	173.5	134	40	36

TBC/XBC Series Standard Cylinder



Main Dimension

TBCD $\Phi 32-\Phi 160$

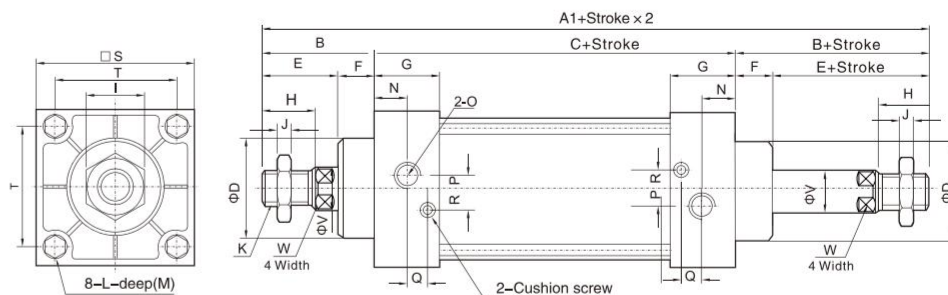

Bore/Sign	A1	B	C	D	E	F	G	H	I	J	K	L
32	187	47	93	26	32	15	27.5	22	17	6	M10X1.25	M6X1
40	191	49	93	32	34	15	27.5	24	17	7	M12X1.25	M6X1
50	207	57	93	38	42	15	27.5	32	23	8	M16X1.5	M6X1
63	210	57	96	38	42	15	27.5	32	23	8	M16X1.5	M8X1.25
80	257	75	107	46	54	21	33	40	26	10	M20X1.5	M10X1.5
100	263	75	113	46	54	21	33	40	26	10	M20X1.5	M10X1.5
125	306	88	130	52	66	20	38	54	41	13.5	M27X2.0	M12X1.75
160	367	113	141	62	88	25	38	72	55	18	M36X2.0	M16X2.0

Bore/Sign	M	N	O	P	Q	R	S	T	V	W
32	13	14	1/8"	3.5	7	6.5	45	33	12	10
40	13	13.5	1/4"	5	5.5	8.5	50	37	16	14
50	13	14.5	1/4"	8.5	3	11	62	47	20	17
63	13	15	3/8"	7	5	9.5	75	56	20	17
80	15.5	16.5	3/8"	7	8	10	94	70	25	22
100	15.5	16.5	1/2"	7.5	8	13	112	84	25	22
125	19	19	1/2"	15	5	15	137.5	104	32	27
160	19.5	19	3/4"	15	6	15	173.5	134	40	36

Note: 1. With magnet and no magnet, the dimensions are same.
2. XBC series dimensions are same as TBC.

TBCJ $\Phi 32-\Phi 160$

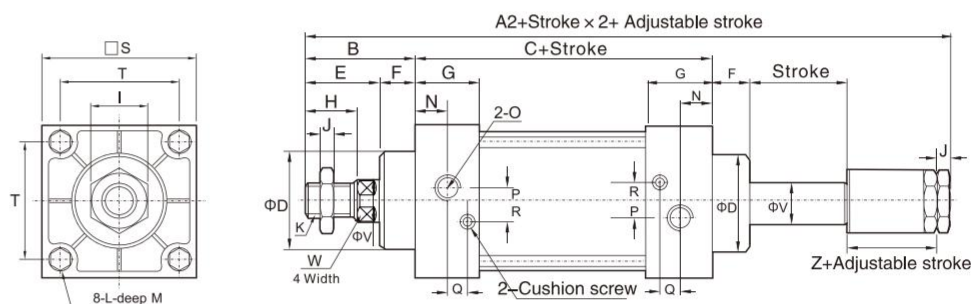

Bore/Sign	A2	B	C	D	E	F	G	H	I	J	K	L
32	182	47	93	26	32	15	27.5	22	17	6	M10X1.25	M6X1
40	185	49	93	32	34	15	27.5	24	17	7	M12X1.25	M6X1
50	196	57	93	38	42	15	27.5	32	23	8	M16X1.5	M6X1
63	199	57	96	38	42	15	27.5	32	23	8	M16X1.5	M8X1.25
80	242	75	107	46	54	21	33	40	26	10	M20X1.5	M10X1.5
100	248	75	113	46	54	21	33	40	26	10	M20X1.5	M10X1.5
125	286.5	88	130	52	68	20	38	54	41	13.5	M27X2.0	M12X1.75
160	337	113	141	62	88	25	38	72	55	18	M36X2.0	M16X2.0

Bore/Sign	M	N	O	P	Q	R	S	T	V	W	Z
32	13	14	1/8"	3.5	7	6.5	45	33	12	10	21
40	13	13.5	1/4"	5	5.5	8.5	50	37	16	14	21
50	13	14.5	1/4"	8.5	3	11	62	47	20	17	23
63	13	15	3/8"	7	5	9.5	75	56	20	17	23
80	15.5	16.5	3/8"	7	8	10	94	70	25	22	29
100	15.5	16.5	1/2"	7.5	8	13	112	84	25	22	29
125	19	19	1/2"	15	5	15	137.5	104	32	27	35
160	19.5	19	3/4"	15	6	15	173.5	134	40	36	40

TBC/XBC 4

Main Dimension

TBCT $\Phi 32 - \Phi 100$

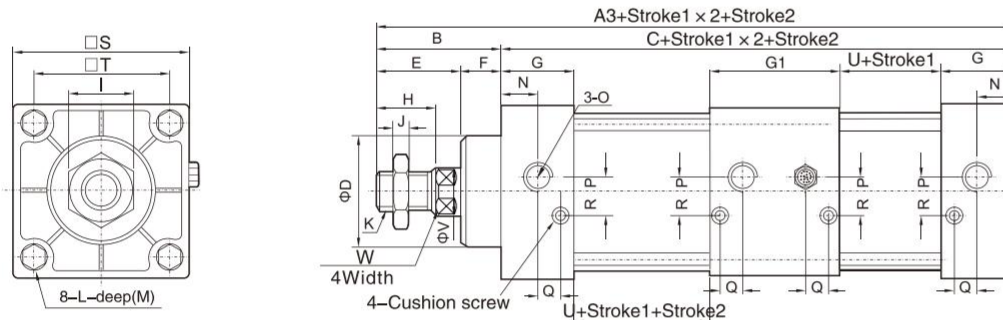

Bore/Sign	A3	B	C	D	E	F	G	G1	H	I	J	K	L
32	233	47	186	26	32	15	27.5	55	22	17	6	M10X1.25	M6X1
40	235	49	186	32	34	15	27.5	55	24	17	7	M12X1.25	M6X1
50	243	57	186	38	42	15	27.5	55	32	23	8	M16X1.5	M6X1
63	249	57	192	38	42	15	27.5	55	32	23	8	M16X1.5	M8X1.25
80	296	75	221	46	54	21	33	73	40	26	10	M20X1.5	M10X1.5
100	308	75	233	46	54	21	33	73	40	26	10	M20X1.5	M10X1.5
Bore/Sign	M	N	O	P	Q	R	S	T	V	U	W		
32	13	14	1/8"	3.5	7	6.5	45	33	12	38	10		
40	13	13.5	1/4"	5	5.5	8.5	50	37	16	38	14		
50	13	14.5	1/4"	8.5	3	11	62	47	20	38	17		
63	13	15	3/8"	7	5	9.5	75	56	20	41	17		
80	15.5	16.5	3/8"	7	8	10	94	70	25	41	22		
100	15.5	16.5	1/2"	7.5	8	13	112	84	25	47	22		

Note: 1. With magnet and no magnet, the dimensions are same. 2. XBC series dimensions are same as TBC.

TBC/XBC Series Standard Cylinder



Dimension of Mounting Accessories

LB



Bore	Model\Sign	AA	AC	AD	AE	AF	AG	AH	AP	AT
32	FJ-TBC32LB	153	134	9.5	50	33	20.5	28	9	3
40	FJ-TBC40LB	169	140	14.5	57	36	23.5	30	12	3
50	FJ-TBC50LB	173	149	12	68	47	28	36.5	12	3
63	FJ-TBC63LB	184	158	13	80	56	31	41	12	3
80	FJ-TBC80LB	199	167	16	97	70	30	49	14	4
100	FJ-TBC100LB	209	173	18	112	84	30	57	14	4

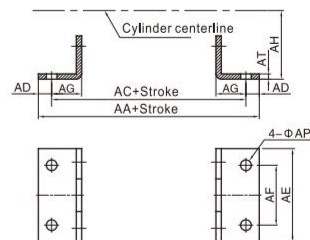

FA/FB



Bore	Model\Sign	AJ	AK	BA	BB	BC	BD	BE	BF	BH	BP	T
32	FJ-TBC32FA	11	7	28.5	10	47	33	72	58	6.5	7	33
40	FJ-TBC40FA	11	7	32.5	10	52	36	84	70	6.5	7	37
50	FJ-TBC50FA	11	7	38.5	10	65	47	104	86	6.5	9	47
63	FJ-TBC63FA	14	9	38.5	12	73	56	115	98	8.5	9	56
80	FJ-TBC80FA	17	11	47.5	16	92	70	141	119	10.5	11	70
100	FJ-TBC100FA	17	11	47.5	16	113	84	160	138	10.5	11	84

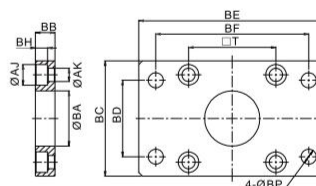

CA



Bore	Model\Sign	DA	DC	DE	DJ	DP	DQ	DZ	S	T
32	FJ-TBC32CA	48	34	12	10	7	16	5.5	44	33
40	FJ-TBC40CA	48.5	34	14	10.5	7	20	5.5	49.5	37
50	FJ-TBC50CA	48.5	33	14	10.5	7	20	6.5	62	47
63	FJ-TBC63CA	50	34	14	10.5	9	20	6.5	72	56
80	FJ-TBC80CA	66.5	48	20	13	11	32	10	92	70
100	FJ-TBC100CA	65.5	48.5	20	13	11	32	10	110	84

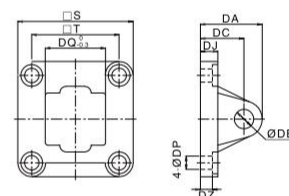

CB



Bore	Model\Sign	DA	DC	DE	DJ	DP	DQ	DT	S	T
32	FJ-TBC32CB	32.5	19.5	12	10	7	16.5	32.5	47	33
40	FJ-TBC40CB	32.5	19.5	14	10.5	7	20.5	44	50	37
50	FJ-TBC50CB	34	19	14	10.5	7	20.5	52	62	47
63	FJ-TBC63CB	34	22	14	10	9	20.5	52	72	56
80	FJ-TBC80CB	50	32	20	13	11	32.5	64	93	70
100	FJ-TBC100CB	51	32	20	13.5	11	32.5	64	110	84

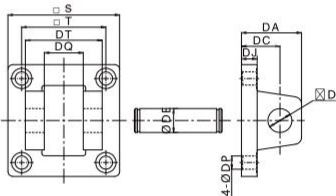

TC



Bore	Model\Sign	EA	EB	EC	EE	EP	ET	T
32	FJ-TBC32TC	38	89	54	55	16	31	33
40	FJ-TBC40TC	46	116	65	63	25	30.5	37
50	FJ-TBC50TC	56	127	76	75	25	29	47
63	FJ-TBC63TC	69.5	140.5	90	88	25	31	56
80	FJ-TBC80TC	87.5	165	107	114	25	36	70
100	FJ-TBC100TC	107.5	181	131	132	25	41	84

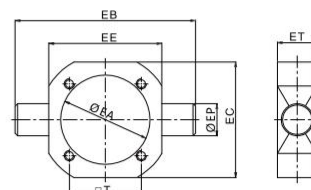

TCM



Bore	Model\Sign	HA	HB	HD	HP	HT	HQ	HJ
32	FJ-TBC32TCM	110.5	80	16	12	13	21.5	51
40/50/63	FJ-TBC40TCM	111.5	80	25.5	12	10.5	21	50.5
80/100	FJ-TBC80TCM	110	85	25.5	14	15	20.5	71

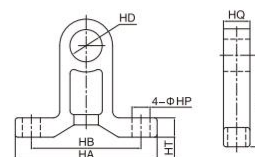

TBC/XBC 4