

SZPY without Buffer



How to Order?

Series No.	Pad Diameter	Pad Model	Pad Material	Vacuum Inlet Mounting				Installation and Connection Mode		
SZPY:	02: Ø2	16: Ø16	N: NBR	Code	Mounting	Thread Diameter	Ø2~Ø8	Ø10~Ø16	Ø20~Ø32	Ø40~Ø50
SZPY Series	04: Ø4	20: Ø20	S: Silicone	N4	Barb Fitting	Ø4 nylon tube	•	•	•	
	06: Ø6	25: Ø25	Rubber	N6		Ø6 nylon tube	•	•	•	•
	08: Ø8	32: Ø32		U4		Ø4 Pu tube	•	•	•	
	10: Ø10	40: Ø40		U6		Ø6 Pu tube	•	•	•	•
	13: Ø13	50: Ø50								

Code	Pad Type	Pad Diameter											
U	Flat type	Ø2	Ø4	Ø6	Ø8	Ø10	Ø13	Ø16	Ø20	Ø25	Ø32	Ø40	Ø50
C	Flat Type with ribs	Ø10 Ø13 Ø16 Ø20 Ø25 Ø32 Ø40 Ø50											
D	Deep type	Ø10 Ø16 Ø25 Ø40											
B	Bellows type	Ø6 Ø8 Ø10 Ø13 Ø16 Ø20 Ø25 Ø32 Ø40 Ø50											

Code	Mounting	Thread Diameter	Ø2~Ø8	Ø10~Ø16	Ø20~Ø32	Ø40~Ø50
A5	Male Thread	M5X0.8	•	•		
A6		M6X1		•	•	•
A8		M8X1			•	•
B4	Female Thread	M4X0.7	•			
B5		M5X0.8	•	•	•	
B6		M6X1		•	•	•
B8		M8X1.25			•	•

Order Example: SZPY series vacuum pad without buffer, pad diameter φ 10, flat type, NBR, vacuum inlet connection: barb fitting φ 4 nylon tube; Installation and connection mode: male thread, thread diameter M5X0.8. ERP code is SZPY10UN-N4-A5.

Installation Method: Male Thread

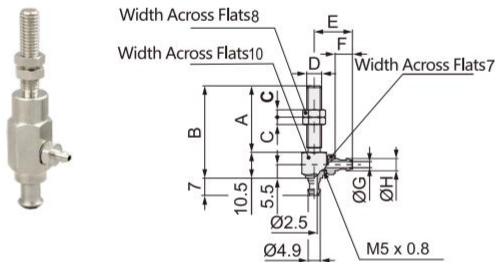

Model	A	B	C	D	E	F	G	H
SZPY1-N4-A5	21.5	32	4	M5X0.8	13.5	5	1.8	2.8
SZPY1-U4-A5					13.5	5	1.8	3.4
SZPY1-N6-A5					15.5	7	2.5	4.5
SZPY1-U6-A5					15.5	7	2.5	4.95
SZPY1-N4-A6	27	37.5	3	M6X1.0	13.5	5	1.8	2.8
SZPY1-U4-A6					13.5	5	1.8	3.4
SZPY1-N6-A6					15.5	7	2.5	4.5
SZPY1-U6-A6					15.5	7	2.5	4.95

Installation Method: Female Thread

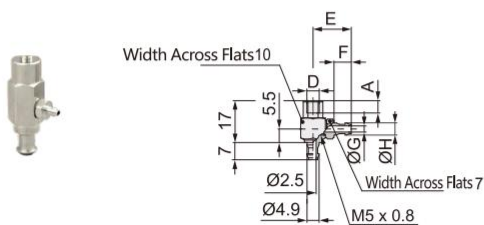

Model	A	D	E	F	G	H
SZPY1-N4-B4	4	M4X0.7	13.5	5	1.8	2.8
SZPY1-U4-B4			13.5	5	1.8	3.4
SZPY1-N6-B4			15.5	7	2.5	4.5
SZPY1-U6-B4			15.5	7	2.5	4.95
SZPY1-N4-B5	5	M5X0.8	13.5	5	1.8	2.8
SZPY1-U4-B5			13.5	5	1.8	3.4
SZPY1-N6-B5			15.5	7	2.5	4.5
SZPY1-U6-B5			15.5	7	2.5	4.95

SZPY Series without Buffer



Flat Type (U) Pads : 02, 04, 06, 08

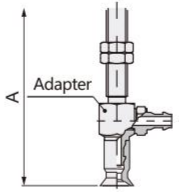

Installation Method: Male Thread

Model	A	Adapter
SZPY○U□-N4-A5	44	SZPY1-N4-A5
SZPY○U□-U4-A5		SZPY1-U4-A5
SZPY○U□-N6-A5		SZPY1-N6-A5
SZPY○U□-U6-A5		SZPY1-U6-A5
SZPY○U□-N4-A6	49.5	SZPY1-N4-A6
SZPY○U□-U4-A6		SZPY1-U4-A6
SZPY○U□-N6-A6		SZPY1-N6-A6
SZPY○U□-U6-A6		SZPY1-U6-A6

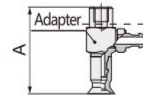

Installation Method: Female Thread

Model	A	Adapter
SZPY○U□-N4-B4	29	SZPY1-N4-B4
SZPY○U□-U4-B4		SZPY1-U4-B4
SZPY○U□-N6-B4		SZPY1-N6-B4
SZPY○U□-U6-B4		SZPY1-U6-B4
SZPY○U□-N4-B5	29	SZPY1-N4-B5
SZPY○U□-U4-B5		SZPY1-U4-B5
SZPY○U□-N6-B5		SZPY1-N6-B5
SZPY○U□-U6-B5		SZPY1-U6-B5

Bellows Type (B) Pads : 06, 08

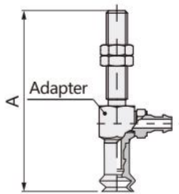

Installation Method: Male Thread

Model	A	Adapter
SZPY○B□-N4-A5	44	SZPY1-N4-A5
SZPY○B□-U4-A5		SZPY1-U4-A5
SZPY○B□-N6-A5		SZPY1-N6-A5
SZPY○B□-U6-A5		SZPY1-U6-A5
SZPY○B□-N4-A6	49.5	SZPY1-N4-A6
SZPY○B□-U4-A6		SZPY1-U4-A6
SZPY○B□-N6-A6		SZPY1-N6-A6
SZPY○B□-U6-A6		SZPY1-U6-A6

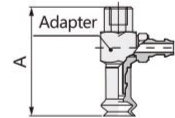

Installation Method: Female Thread

Model	A	Adapter
SZPY○B□-N4-B4	29	SZPY1-N4-B4
SZPY○B□-U4-B4		SZPY1-U4-B4
SZPY○B□-N6-B4		SZPY1-N6-B4
SZPY○B□-U6-B4		SZPY1-U6-B4
SZPY○B□-N4-B5	29	SZPY1-N4-B5
SZPY○B□-U4-B5		SZPY1-U4-B5
SZPY○B□-N6-B5		SZPY1-N6-B5
SZPY○B□-U6-B5		SZPY1-U6-B5

Flat Type (U) Pads : 10,13,16

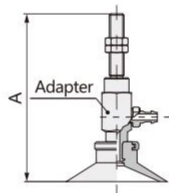

Model	Pads			A	①Adapter
	10	13	16		
SZPY○U□-N4-A5	59	59	59.5	59.5	SZPY2-N4-A5
SZPY○U□-U4-A5					SZPY2-U4-A5
SZPY○U□-N6-A5					SZPY2-N6-A5
SZPY○U□-U6-A5					SZPY2-U6-A5
SZPY○U□-N4-A6	64	64	64.5	64.5	SZPY2-N4-A6
SZPY○U□-U4-A6					SZPY2-U4-A6
SZPY○U□-N6-A6					SZPY2-N6-A6
SZPY○U□-U6-A6					SZPY2-U6-A6

Flat Type with Ribs (C) Pads : 10,13,16

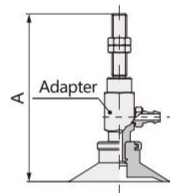

Model	Pads			A	①Adapter
	10	13	16		
SZPY○C□-N4-A5	59	59	59.5	59.5	SZPY2-N4-A5
SZPY○C□-U4-A5					SZPY2-U4-A5
SZPY○C□-N6-A5					SZPY2-N6-A5
SZPY○C□-U6-A5					SZPY2-U6-A5
SZPY○C□-N4-A6	64	64	64.5	64.5	SZPY2-N4-A6
SZPY○C□-U4-A6					SZPY2-U4-A6
SZPY○C□-N6-A6					SZPY2-N6-A6
SZPY○C□-U6-A6					SZPY2-U6-A6

Bellows Type (B) Pads : 10,13,16

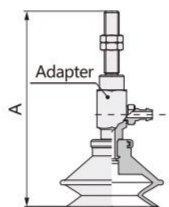

Model	Pads			A	①Adapter
	10	13	16		
SZPY○B□-N4-A5	63	65.5	67	67	SZPY2-N4-A5
SZPY○B□-U4-A5					SZPY2-U4-A5
SZPY○B□-N6-A5					SZPY2-N6-A5
SZPY○B□-U6-A5					SZPY2-U6-A5
SZPY○B□-N4-A6	68	70.5	72	72	SZPY2-N4-A6
SZPY○B□-U4-A6					SZPY2-U4-A6
SZPY○B□-N6-A6					SZPY2-N6-A6
SZPY○B□-U6-A6					SZPY2-U6-A6

Deep Type (D) Pads : 10,16

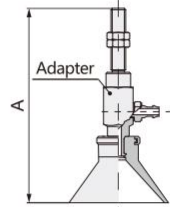

Model	Pads		A	①Adapter
	10	16		
SZPY○D□-N4-A5	62	67	67	SZPY2-N4-A5
SZPY○D□-U4-A5				SZPY2-U4-A5
SZPY○D□-N6-A5				SZPY2-N6-A5
SZPY○D□-U6-A5				SZPY2-U6-A5
SZPY○D□-N4-A6	63	68	68	SZPY2-N4-A6
SZPY○D□-U4-A6				SZPY2-U4-A6
SZPY○D□-N6-A6				SZPY2-N6-A6
SZPY○D□-U6-A6				SZPY2-U6-A6

Adapter Type

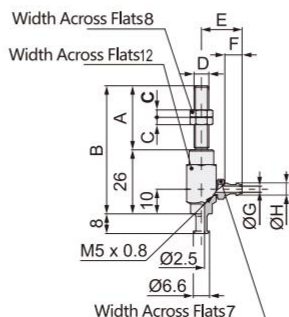

Model	A	B	C	D	E	F	G	H
SZPY2-N4-A5	21	47	4	M5X0.8	14.5	5	1.8	2.8
SZPY2-U4-A5					14.5	5	1.8	3.4
SZPY2-N6-A5					16.5	7	2.5	4.5
SZPY2-U6-A5	26	52	3	M6X1.0	16.5	7	2.5	4.95
SZPY2-N4-A6					14.5	5	1.8	2.8
SZPY2-U4-A6					14.5	5	1.8	3.4
SZPY2-N6-A6					16.5	7	2.5	4.5
SZPY2-U6-A6	26	52	3	M6X1.0	16.5	7	2.5	4.95
SZPY2-U6-A6					16.5	7	2.5	4.95

SZPY without Buffer

SZPY Series without Buffer



Flat Type (U) Pads : 10,13,16

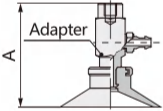

Model	Pads			A	①Adapter
	10	13	16		
SZPY○U□-N4-B5	38	38	38.5	SZPY2-N4-B5	
SZPY○U□-U4-B5				SZPY2-U4-B5	
SZPY○U□-N6-B5				SZPY2-N6-B5	
SZPY○U□-U6-B5				SZPY2-U6-B5	
SZPY○U□-N4-B6				SZPY2-N4-B6	
SZPY○U□-U4-B6				SZPY2-U4-B6	
SZPY○U□-N6-B6				SZPY2-N6-B6	
SZPY○U□-U6-B6				SZPY2-U6-B6	

Flat Type with Ribs (C) Pads : 10,13,16

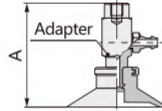

Model	Pads			A	①Adapter
	10	13	16		
SZPY○C□-N4-B5	38	38	38.5	SZPY2-N4-B5	
SZPY○C□-U4-B5				SZPY2-U4-B5	
SZPY○C□-N6-B5				SZPY2-N6-B5	
SZPY○C□-U6-B5				SZPY2-U6-B5	
SZPY○C□-N4-B6				SZPY2-N4-B6	
SZPY○C□-U4-B6				SZPY2-U4-B6	
SZPY○C□-N6-B6				SZPY2-N6-B6	
SZPY○C□-U6-B6				SZPY2-U6-B6	

Bellows Type (B) Pads : 10,13,16

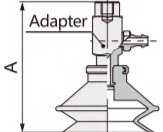

Model	Pads			A	①Adapter
	10	13	16		
SZPY○B□-N4-B5	42	44.5	46	SZPY2-N4-B5	
SZPY○B□-U4-B5				SZPY2-U4-B5	
SZPY○B□-N6-B5				SZPY2-N6-B5	
SZPY○B□-U6-B5				SZPY2-U6-B5	
SZPY○B□-N4-B6				SZPY2-N4-B6	
SZPY○B□-U4-B6				SZPY2-U4-B6	
SZPY○B□-N6-B6				SZPY2-N6-B6	
SZPY○B□-U6-B6				SZPY2-U6-B6	

Deep Type (D) Pads : 10,16

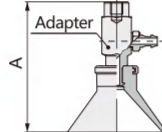

Model	Pads		A	①Adapter
	10	16		
SZPY○D□-N4-B5	41	42	SZPY2-N4-B5	
SZPY○D□-U4-B5			SZPY2-U4-B5	
SZPY○D□-N6-B5			SZPY2-N6-B5	
SZPY○D□-U6-B5			SZPY2-U6-B5	
SZPY○D□-N4-B6			SZPY2-N4-B6	
SZPY○D□-U4-B6			SZPY2-U4-B6	
SZPY○D□-N6-B6			SZPY2-N6-B6	
SZPY○D□-U6-B6			SZPY2-U6-B6	

Adapter Type

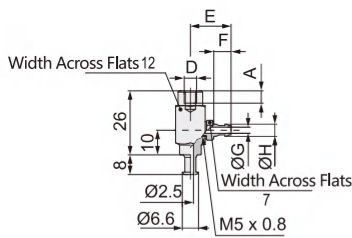

Model	A	D	E	F	G	H
SZPY2-N4-B5	5	M5X0.8	14.5	5	1.8	2.8
SZPY2-U4-B5			14.5	5	1.8	3.4
SZPY2-N6-B5			16.5	7	2.5	4.5
SZPY2-U6-B5	6	M6X1.0	16.5	7	2.5	4.95
SZPY2-N4-B6			14.5	5	1.8	2.8
SZPY2-U4-B6			14.5	5	1.8	3.4
SZPY2-N6-B6			16.5	7	2.5	4.5
SZPY2-U6-B6			16.5	7	2.5	4.95

Flat Type (U) Pads : 20,25,32

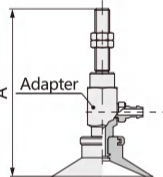

Model	Pads			A	①Adapter		
	20	25	32				
SZPY○U□-N4-A6	68	68	68.5	SZPY3-N4-A6			
SZPY○U□-U4-A6				SZPY3-U4-A6			
SZPY○U□-N6-A6				SZPY3-N6-A6			
SZPY○U□-U6-A6				SZPY3-U6-A6			
SZPY○U□-N4-A8				58	58	58.5	SZPY3-N4-A8
SZPY○U□-U4-A8							SZPY3-U4-A8
SZPY○U□-N6-A8							SZPY3-N6-A8
SZPY○U□-U6-A8							SZPY3-U6-A8

Flat Type with Ribs (C) Pads : 20,25,32

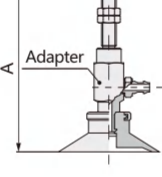

Model	Pads			A	①Adapter		
	20	25	32				
SZPYC□-N4-A6	68	68	68.5	SZPY3-N4-A6			
SZPYC□-U4-A6				SZPY3-U4-A6			
SZPYC□-N6-A6				SZPY3-N6-A6			
SZPYC□-U6-A6				SZPY3-U6-A6			
SZPYC□-N4-A8				58	58	58.5	SZPY3-N4-A8
SZPYC□-U4-A8							SZPY3-U4-A8
SZPYC□-N6-A8							SZPY3-N6-A8
SZPYC□-U6-A8							SZPY3-U6-A8

Bellows Type (B) Pads : 20,25,32

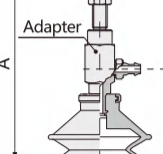

Model	Pads			A	①Adapter
	20	25	32		
SZPY○B□-N4-A6	79.5	80	85	SZPY3-N4-A6	
SZPY○B□-U4-A6				SZPY3-U4-A6	
SZPY○B□-N6-A6				SZPY3-N6-A6	
SZPY○B□-U6-A6				SZPY3-U6-A6	
SZPY○B□-N4-A8				69.5	70
SZPY○B□-U4-A8	SZPY3-U4-A8				
SZPY○B□-N6-A8	SZPY3-N6-A8				
SZPY○B□-U6-A8	SZPY3-U6-A8				

Deep Type (D) Pads : 25

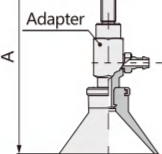

Model	A	①Adapter
SZPY25D□-N4-A6	74	SZPY3N4-A6
SZPY25D□-U4-A6		SZPY3-U4-A6
SZPY25D□-N6-A6		SZPY3-N6-A6
SZPY25D□-U6-A6	64	SZPY3-U6-A6
SZPY25D□-N4-A8		SZPY3-N4-A8
SZPY25D□-U4-A8		SZPY3-U4-A8
SZPY25D□-N6-A8		SZPY3-N6-A8
SZPY25D□-U6-A8		SZPY3-U6-A8

SZPY without Buffer

SZPY Series without Buffer



Adapter Type

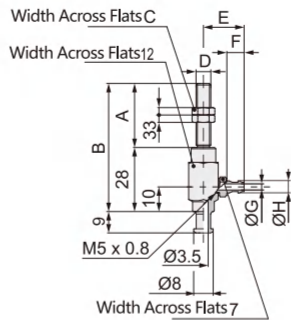

Model	A	B	C	D	E	F	G	H
SZPY3-N4-A6	26	54	8	M6X1.0	14.5	5	1.8	2.8
SZPY3-U4-A6					14.5	5	1.8	3.4
SZPY3-N6-A6					16.5	7	2.5	4.5
SZPY3-U6-A6					16.5	7	2.5	4.95
SZPY3-N4-A8	16	44	12	M8X1.0	14.5	5	1.8	2.8
SZPY3-U4-A8					14.5	5	1.8	3.4
SZPY3-N6-A8					16.5	7	2.5	4.5
SZPY3-U6-A8					16.5	7	2.5	4.95

Flat Type (U) Pads : 20, 25, 32



Model	Pads			A	Adapter
	20	25	32		
SZPY-U-N4-B5	42	42	42.5		SZPY3-N4-B5
SZPY-U-U4-B5					SZPY3-U4-B5
SZPY-U-N6-B5					SZPY3-N6-B5
SZPY-U-U6-B5					SZPY3-U6-B5
SZPY-U-N4-B6					SZPY3-N4-B6
SZPY-U-U4-B6					SZPY3-U4-B6
SZPY-U-N6-B6					SZPY3-N6-B6
SZPY-U-U6-B6					SZPY3-U6-B6
SZPY-U-N4-B8					SZPY3-N4-B8
SZPY-U-U4-B8					SZPY3-U4-B8
SZPY-U-N6-B8					SZPY3-N6-B8
SZPY-U-U6-B8					SZPY3-U6-B8

Flat Type with Ribs (C) Pads : 20, 25, 32



Model	Pads			A	Adapter
	20	25	32		
SZPY-C-N4-B5	42	42	42.5		SZPY3-N4-B5
SZPY-C-U4-B5					SZPY3-U4-B5
SZPY-C-N6-B5					SZPY3-N6-B5
SZPY-C-U6-B5					SZPY3-U6-B5
SZPY-C-N4-B6					SZPY3-N4-B6
SZPY-C-U4-B6					SZPY3-U4-B6
SZPY-C-N6-B6					SZPY3-N6-B6
SZPY-C-U6-B6					SZPY3-U6-B6
SZPY-C-N4-B8					SZPY3-N4-B8
SZPY-C-U4-B8					SZPY3-U4-B8
SZPY-C-N6-B8					SZPY3-N6-B8
SZPY-C-U6-B8					SZPY3-U6-B8

Bellows Type (B) Pads : 20, 25, 32



Model	Pads			A	Adapter
	20	25	32		
SZPY-B-N4-B5	51.5	52	57		SZPY3-N4-B5
SZPY-B-U4-B5					SZPY3-U4-B5
SZPY-B-N6-B5					SZPY3-N6-B5
SZPY-B-U6-B5					SZPY3-U6-B5
SZPY-B-N4-B6					SZPY3-N4-B6
SZPY-B-U4-B6					SZPY3-U4-B6
SZPY-B-N6-B6					SZPY3-N6-B6
SZPY-B-U6-B6					SZPY3-U6-B6
SZPY-B-N4-B8					SZPY3-N4-B8
SZPY-B-U4-B8					SZPY3-U4-B8
SZPY-B-N6-B8					SZPY3-N6-B8
SZPY-B-U6-B8					SZPY3-U6-B8

Deep Type (D) Pads : 25



Model	A	Adapter
SZPY25D-N4-B5	48	SZPY3-N4-B5
SZPY25D-U4-B5		SZPY3-U4-B5
SZPY25D-N6-B5		SZPY3-N6-B5
SZPY25D-U6-B5		SZPY3-U6-B5
SZPY25D-N4-B6		SZPY3-N4-B6
SZPY25D-U4-B6		SZPY3-U4-B6
SZPY25D-N6-B6		SZPY3-N6-B6
SZPY25D-U6-B6		SZPY3-U6-B6
SZPY25D-N4-B8		SZPY3-N4-B8
SZPY25D-U4-B8		SZPY3-U4-B8
SZPY25D-N6-B8		SZPY3-N6-B8
SZPY25D-U6-B8		SZPY3-U6-B8

Adapter Type

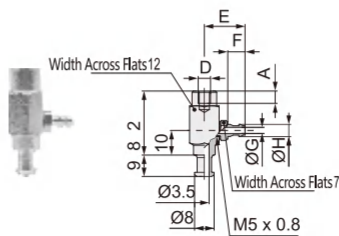

Model	A	D	E	F	G	H
SZPY3-N4-B5	5	M5X0.8	14.5	5	1.8	2.8
SZPY3-U4-B5			14.5	5	1.8	3.4
SZPY3-N6-B5			16.5	7	2.5	4.5
SZPY3-U6-B5	6	M6X1.0	16.5	7	2.5	4.95
SZPY3-N4-B6			14.5	5	1.8	2.8
SZPY3-U4-B6			14.5	5	1.8	3.4
SZPY3-N6-B6			16.5	7	2.5	4.5
SZPY3-U6-B6	8	M8X1.0	16.5	7	2.5	4.95
SZPY3-N4-B8			14.5	5	1.8	2.8
SZPY3-U4-B8			14.5	5	1.8	3.4
SZPY3-N6-B8			16.5	7	2.5	4.5
SZPY3-U6-B8			16.5	7	2.5	4.95

SZPY without Buffer

Flat Type (U) Pads : 40,50

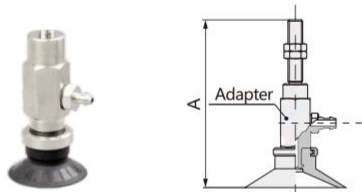

Model	Pads A		①Adapter
	40	50	
SZPY○U□-N6-A6	72.5	62.5	SZPY4-N6-A6
SZPY○U□-U6-A6			SZPY4-U6-A6
SZPY○U□-N6-A8	73.5	63.5	SZPY4-N6-A8
SZPY○U□-U6-A8			SZPY4-U6-A8

Flat Type with Ribs (C) Pads : 40,50

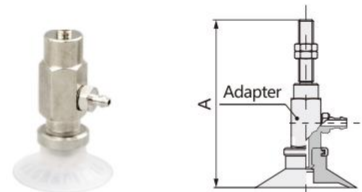

Model	Pads A		①Adapter
	40	50	
SZPY○C□-N6-A6	72.5	62.5	SZPY4-N6-A6
SZPY○C□-U6-A6			SZPY4-U6-A6
SZPY○C□-N6-A8	73.5	63.5	SZPY4-N6-A8
SZPY○C□-U6-A8			SZPY4-U6-A8

Bellows Type (B) Pads : 40,50

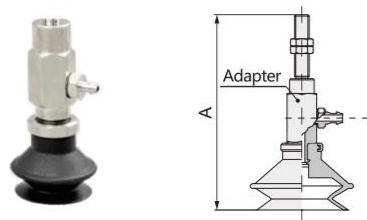

Model	Pads A		①Adapter
	40	50	
SZPY○B□-N6-A6	88	78	SZPY4-N6-A6
SZPY○B□-U6-A6			SZPY4-U6-A6
SZPY○B□-N6-A8	92	82	SZPY4-N6-A8
SZPY○B□-U6-A8			SZPY4-U6-A8

Deep Typel (D) Pads : 40

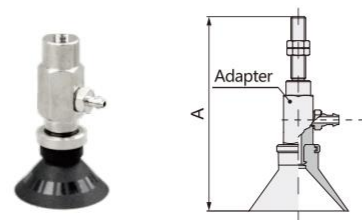

Model	A	①Adapter
SZPY40D□-N6-A6	83	SZPY4-N6-A6
SZPY40D□-U6-A6		SZPY4-U6-A6
SZPY40D□-N6-A8	73	SZPY4-N6-A8
SZPY40D□-U6-A8		SZPY4-U6-A8

Adapter Type

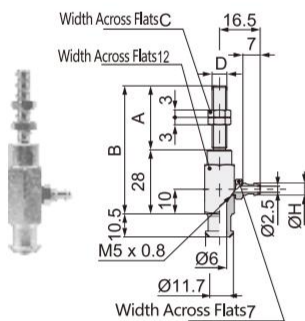

Model	A	B	C	D	H
SZPY4-N6-A6	26	54	8	M6X1.0	4.5
SZPY4-U6-A6					4.95
SZPY4-N6-A8	16	44	12	M8X1.0	4.5
SZPY4-U6-A8					4.95

