

## SZPR with Buffer



### How to Order?

Series No.	Pad Diameter Model	Pad Material	Buffer Model	Buffer Stroke	Vacuum Inlet Mounting	Installation Connection
SZPR: SZPR Series		N: NBR S: Silicone Rubber				
02:Ø2	16:Ø16					
04:Ø4	20:Ø20					
06:Ø6	25:Ø25					
08:Ø8	32:Ø32					
10:Ø10	40:Ø40					
13:Ø13	50:Ø50					

Code	Buffer Type	Code	Ø2~Ø8	Ø10~Ø32	Ø40~Ø50
Rotating J		6	•		
		10	•	•	•
		15	•		
		20		•	•
		25	•		
		30		•	•
Non-Rotating K		40		•	
		50		•	•

Code	Thread Diameter	Ø2~Ø8	Ø10~Ø32	Ø40~Ø50
A8	M8×1.0	•		
A10	M10×1.0		•	
A14	M14×1.0			•

  

Code	Mounting	Thread Diameter	Ø2~Ø8	Ø10~Ø32	Ø40~Ø50
04	Quick Fitting	Ø4 tube	•	•	
06		Ø6 tube	•	•	•
08		Ø8 tube			•

Code	Pad Type	Pad Diameter	Spring Reactive Force (N)
U	Flat type	Ø2 Ø4 Ø6 Ø8 Ø10 Ø13 Ø16 Ø20 Ø25 Ø32 Ø40 Ø50	At 0 Stroke: 0.8N, 1.2N
C	Flat Type with ribs	Ø10 Ø13 Ø16 Ø20 Ø25 Ø32 Ø40 Ø50	At Full Stroke: 1.0N, 3.0N
D	Deep type	Ø10 Ø16 Ø25 Ø40	2.0N, 5.0N
B	Bellows type	Ø6 Ø8 Ø10 Ø13 Ø16 Ø20 Ø25 Ø32 Ø40 Ø50	

**Order Example:** Vacuum suction cups SZPR series with cushioning, suction cup Ø 10, parallel suction cups, NBR, non-returnable, cushioning stroke 20, Vacuum Inlet Mounting: quick coupling Ø 06 tube; Mounting connection thread Ø M10 x 1.0. Ordering code: SZPR10UNK20-06-A10.

### SZPR Method of Component Replacement

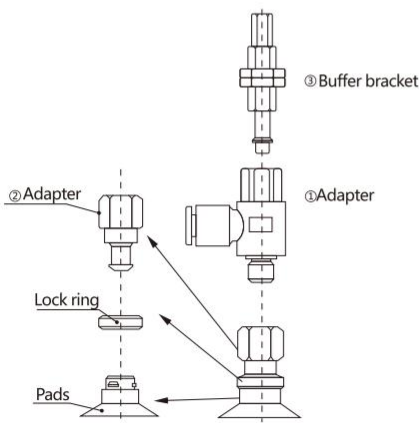

Pad Model SZP R 13 UN K 10 - 06 - A10

Symbol	Pad Diameter	Connecting Thread	Symbol	Thread Diameter
2	10, 16	B5	1	A8
3	20, 32		2	A10
4	40, 50	B8	3	A14

② Adapter SZP R 2 - B5  
① Adapter SZP R S 06 - B5

Symbol	Pad Diameter	Connecting Thread	Pad Diameter
S	02-16	B5	02-32
L	20-50	B8	40-50

② Bracket SZP B 2 - K10 - 06

①+②+③ SZP T 2 - K10 - 06 - A0

## ○ Vacuum Port: Female Thread

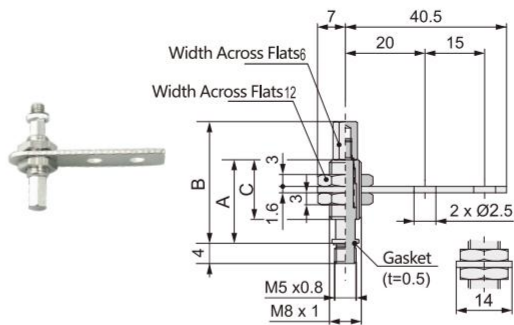

Model	A	B	C
SZPB1J6	21	34	15
SZPB1J10	54	65	43
SZPB1J15	59	70	
SZPB1J25	69	80	

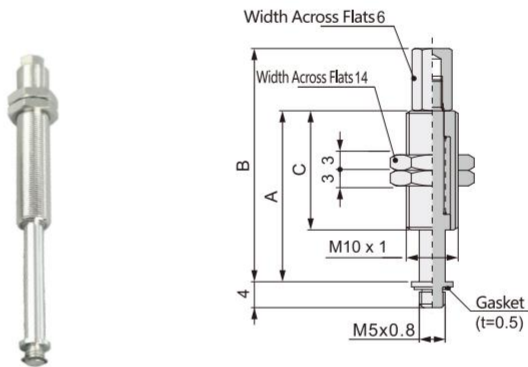

Model	A	B	C
SZPB2J10	34	45	23
SZPB2J20	72	83	51
SZPB2J30	82	93	
SZPB2J40	118	129	
SZPB2J50	128	139	77

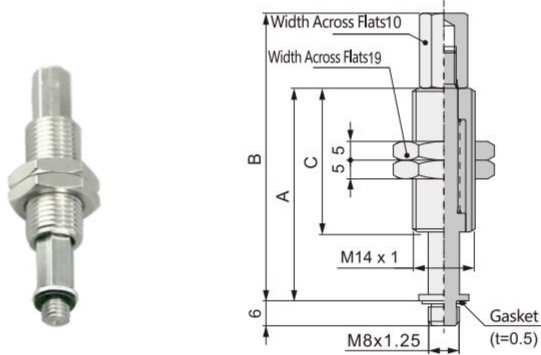

Model	A	B	C
SZPB3J10	62	80	50
SZPB3J20	72	77	
SZPB3J30	82	87	
SZPB3J50	127	132	75

## ○ Flat Type (U) ○ Pads : 02,04,06,08

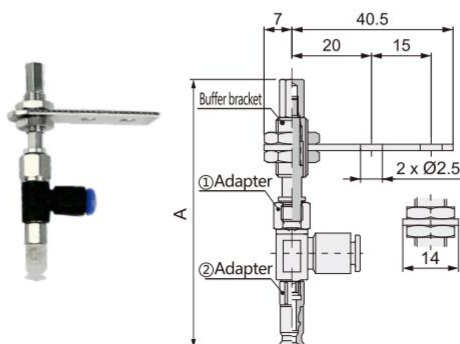

Model	A	Buffer Bracket	①Adapter	②Adapter
SZPRUJ6-04-A8	78.5	SZPB1J6	SZPRS-04-B5	SZPT1-B5
SZPRUJ6-06-A8	78.5	SZPB1J6	SZPRS-06-B5	
SZPRUJ10-04-A8	109.5	SZPB1J10	SZPRS-04-B5	
SZPRUJ10-06-A8	109.5	SZPB1J10	SZPRS-06-B5	
SZPRUJ15-04-A8	114.5	SZPB1J15	SZPRS-04-B5	
SZPRUJ15-06-A8	114.5	SZPB1J15	SZPRS-06-B5	
SZPRUJ25-04-A8	124.5	SZPB1J25	SZPRS-04-B5	
SZPRUJ25-06-A8	124.5	SZPB1J25	SZPRS-06-B5	

◎ Bellows Type (B) ○ Pads : 06,08

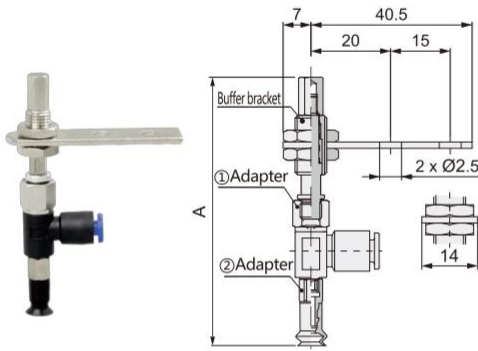

Model	A	Buffer Bracket	①Adapter	②Adapter
SZPR○B□J6-04-A8	79.5	SZPB1J6	SZPRS-04-B5	SZPT1-B5
SZPR○B□J6-06-A8	79.5	SZPB1J6	SZPRS-06-B5	
SZPR○B□J10-04-A8	110.5	SZPB1J10	SZPRS-04-B5	
SZPR○B□J10-06-A8	110.5	SZPB1J10	SZPRS-06-B5	
SZPR○B□J15-04-A8	115.5	SZPB1J15	SZPRS-04-B5	
SZPR○B□J15-06-A8	115.5	SZPB1J15	SZPRS-06-B5	
SZPR○B□J25-04-A8	125.5	SZPB1J25	SZPRS-04-B5	
SZPR○B□J25-06-A8	125.5	SZPB1J25	SZPRS-06-B5	

◎ Flat Type (U) ○ Pads : 10, 13, 16

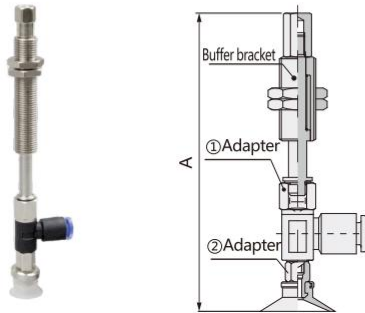

Model	○ Pads A			Buffer Bracket	①Adapter	②Adapter
	10	13	16			
SZPR○U□J10-04-A10	91	91	91.5	SZPB2J6	SZPRS-04-B5	SZPT3-B5
SZPR○U□J10-06-A10	91	91	91.5	SZPB2J6	SZPRS-06-B5	
SZPR○U□J20-04-A10	129	129	129.5	SZPB2J10	SZPRS-04-B5	
SZPR○U□J20-06-A10	129	129	129.5	SZPB2J10	SZPRS-06-B5	
SZPR○U□J30-04-A10	139	139	139.5	SZPB2J15	SZPRS-04-B5	
SZPR○U□J30-06-A10	139	139	139.5	SZPB2J15	SZPRS-06-B5	
SZPR○U□J40-04-A10	175	175	175.5	SZPB2J25	SZPRS-04-B5	
SZPR○U□J40-06-A10	175	175	175.5	SZPB2J25	SZPRS-06-B5	
SZPR○U□J50-04-A10	185	185	185.5	SZPB2J25	SZPRS-04-B5	
SZPR○U□J50-06-A10	185	185	185.5	SZPB2J25	SZPRS-06-B5	

◎ Flat Type with Ribs (C) ○ Pads : 10, 13, 16

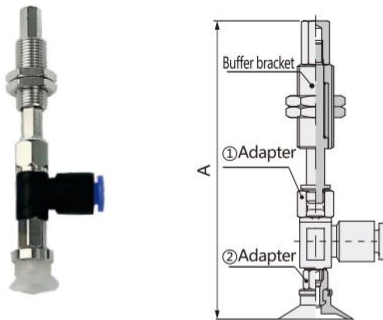

Model	○ Pads A			Buffer Bracket	①Adapter	②Adapter
	10	13	16			
SZPR○C□J10-04-A10	91	91	91.5	SZPB2J10	SZPRS-04-B5	SZPT2-B5
SZPR○C□J10-06-A10	91	91	91.5	SZPB2J10	SZPRS-06-B5	
SZPR○C□J20-04-A10	129	129	129.5	SZPB2J10	SZPRS-04-B5	
SZPR○C□J20-06-A10	129	129	129.5	SZPB2J20	SZPRS-06-B5	
SZPR○C□J30-04-A10	139	139	139.5	SZPB2J30	SZPRS-04-B5	
SZPR○C□J30-06-A10	139	139	139.5	SZPB2J30	SZPRS-06-B5	
SZPR○C□J40-04-A10	175	175	175.5	SZPB2J40	SZPRS-04-B5	
SZPR○C□J40-06-A10	175	175	175.5	SZPB2J40	SZPRS-06-B5	
SZPR○C□J50-04-A10	185	185	185.5	SZPB2J50	SZPRS-04-B5	
SZPR○C□J50-06-A10	185	185	185.5	SZPB2J50	SZPRS-06-B5	

◎ Bellows Type (B) ○ Pads : 10, 13, 16

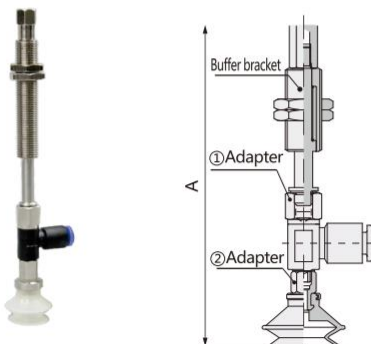

Model	○ Pads A			Buffer Bracket	①Adapter	②Adapter
	10	13	16			
SZPR○B□J10-04-A10	95	97.5	99	SZPB2J10	SZPRS-04-B5	SZPT2-B5
SZPR○B□J10-06-A10	95	97.5	99	SZPB2J10	SZPRS-06-B5	
SZPR○B□J20-04-A10	133	135.5	137	SZPB2J20	SZPRS-04-B5	
SZPR○B□J20-06-A10	133	135.5	137	SZPB2J20	SZPRS-06-B5	
SZPR○B□J30-04-A10	143	145.5	147	SZPB2J30	SZPRS-04-B5	
SZPR○B□J30-06-A10	143	145.5	147	SZPB2J30	SZPRS-06-B5	
SZPR○B□J40-04-A10	179	183	183	SZPB2J40	SZPRS-04-B5	
SZPR○B□J40-06-A10	179	183	183	SZPB2J40	SZPRS-06-B5	
SZPR○B□J50-04-A10	189	193	193	SZPB2J50	SZPRS-04-B5	
SZPR○B□J50-06-A10	189	193	193	SZPB2J50	SZPRS-06-B5	

# SZPR Series with Buffer



## Deep Type (D) Pads : 10, 16

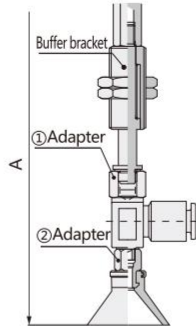

Model	Pads A		Buffer Bracket	①Adapter	②Adapter
	10	16			
SZPR◊D□J10-04-A10	83	84	SZPB2J10	SZPRS-04-B5	SZPT2-B5
SZPR◊D□J10-06-A10	83	84	SZPB2J10	SZPRS-06-B5	
SZPR◊D□J20-04-A10	132	133	SZPB2J20	SZPRS-04-B5	
SZPR◊D□J20-06-A10	132	133	SZPB2J20	SZPRS-06-B5	
SZPR◊D□J30-04-A10	142	143	SZPB2J30	SZPRS-04-B5	
SZPR◊D□J30-06-A10	142	143	SZPB2J30	SZPRS-06-B5	
SZPR◊D□J40-04-A10	178	179	SZPB2J40	SZPRS-04-B5	
SZPR◊D□J40-06-A10	178	179	SZPB2J40	SZPRS-06-B5	
SZPR◊D□J50-04-A10	188	189	SZPB2J50	SZPRS-04-B5	
SZPR◊D□J50-06-A10	188	189	SZPB2J50	SZPRS-06-B5	

## Flat Type (U) Pads : 20,25,32

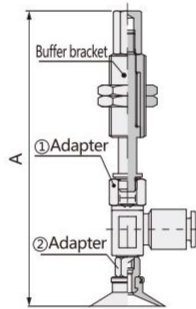

Model	Pads A			Buffer Bracket	①Adapter	②Adapter
	20	25	32			
SZPR◊U□J10-04-A10	102.6	102.6	103.1	SZPB2J10	SZPRL-04-B5	SZPT3-B8
SZPR◊U□J10-06-A10				SZPB2J10	SZPRL-06-B5	
SZPR◊U□J10-08-A10				SZPB2J10	SZPRL-08-B5	
SZPR◊U□J20-04-A10	140.6	140.6	141.1	SZPB2J20	SZPRL-04-B5	
SZPR◊U□J20-06-A10				SZPB2J20	SZPRL-06-B5	
SZPR◊U□J20-08-A10				SZPB2J20	SZPRL-08-B5	
SZPR◊U□J30-04-A10	150.6	150.6	151.1	SZPB2J30	SZPRL-04-B5	
SZPR◊U□J30-06-A10				SZPB2J30	SZPRL-06-B5	
SZPR◊U□J30-08-A10				SZPB2J30	SZPRL-08-B5	
SZPR◊U□J40-04-A10	186.6	186.6	187.1	SZPB2J40	SZPRL-04-B5	
SZPR◊U□J40-06-A10				SZPB2J40	SZPRL-06-B5	
SZPR◊U□J40-08-A10				SZPB2J40	SZPRL-08-B5	
SZPR◊U□J50-04-A10	196.6	196.6	197.1	SZPB2J50	SZPRL-04-B5	
SZPR◊U□J50-06-A10				SZPB2J50	SZPRL-06-B5	
SZPR◊U□J50-08-A10				SZPB2J50	SZPRL-08-B5	

## Flat Type with Ribs (C) Pads : 20,25,32

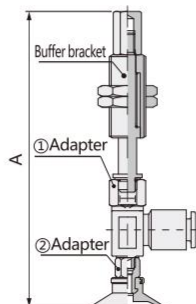

Model	Pads A			Buffer Bracket	①Adapter	②Adapter
	20	25	32			
SZPR◊C□J10-04-A10	102.6	102.6	103.1	SZPB2J10	SZPRL-04-B5	SZPT3-B8
SZPR◊C□J10-06-A10				SZPB2J10	SZPRL-06-B5	
SZPR◊C□J10-08-A10				SZPB2J10	SZPRL-08-B5	
SZPR◊C□J20-04-A10	140.6	140.6	141.1	SZPB2J20	SZPRL-04-B5	
SZPR◊C□J20-06-A10				SZPB2J20	SZPRL-06-B5	
SZPR◊C□J20-08-A10				SZPB2J20	SZPRL-08-B5	
SZPR◊C□J30-04-A10	150.6	150.6	151.1	SZPB2J30	SZPRL-04-B5	
SZPR◊C□J30-06-A10				SZPB2J30	SZPRL-06-B5	
SZPR◊C□J30-08-A10				SZPB2J30	SZPRL-08-B5	
SZPR◊C□J40-04-A10	186.6	186.6	187.1	SZPB2J40	SZPRL-04-B5	
SZPR◊C□J40-06-A10				SZPB2J40	SZPRL-06-B5	
SZPR◊C□J40-08-A10				SZPB2J40	SZPRL-08-B5	
SZPR◊C□J50-04-A10	196.6	196.6	197.1	SZPB2J50	SZPRL-04-B5	
SZPR◊C□J50-06-A10				SZPB2J50	SZPRL-06-B5	
SZPR◊C□J50-08-A10				SZPB2J50	SZPRL-08-B5	

SZPR

## ◎ Bellows Type (B) ○ Pads : 20,25,32

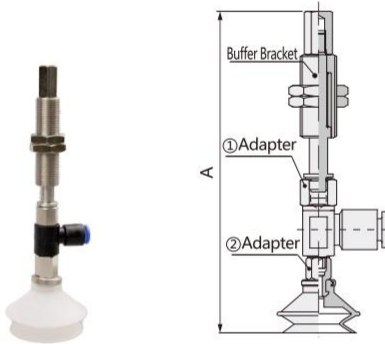

Model	○ Pads A			Buffer Bracket	①Adapter	②Adapter
	20	25	32			
SZPR○B□J10-04-A10	112.1	112.6	117.6	SZPB2J10	SZPRL-04-B5	SZPT3-B8
SZPR○B□J10-06-A10				SZPB2J10	SZPRL-06-B5	
SZPR○B□J10-08-A10				SZPB2J10	SZPRL-08-B5	
SZPR○B□J20-04-A10	150.1	150.6	115.6	SZPB2J20	SZPRL-04-B5	
SZPR○B□J20-06-A10				SZPB2J20	SZPRL-06-B5	
SZPR○B□J20-08-A10				SZPB2J20	SZPRL-08-B5	
SZPR○B□J30-04-A10	160.1	160.6	165.6	SZPB2J30	SZPRL-04-B5	
SZPR○B□J30-06-A10				SZPB2J30	SZPRL-06-B5	
SZPR○B□J30-08-A10				SZPB2J30	SZPRL-08-B5	
SZPR○B□J40-04-A10	196.1	196.6	201.6	SZPB2J40	SZPRL-04-B5	
SZPR○B□J40-06-A10				SZPB2J40	SZPRL-06-B5	
SZPR○B□J40-08-A10				SZPB2J40	SZPRL-08-B5	
SZPR○B□J50-04-A10	206.1	206.6	211.6	SZPB2J50	SZPRL-04-B5	
SZPR○B□J50-06-A10				SZPB2J50	SZPRL-06-B5	
SZPR○B□J50-08-A10				SZPB2J50	SZPRL-08-B5	

## ◎ Deep Type (D) ○ Pads : 25

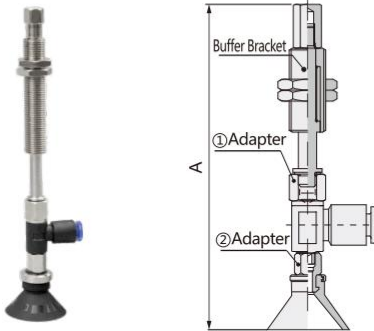

Model	A	Buffer Bracket	①Adapter	②Adapter
SZPR25D□J10-04-A10	108.6	SZPB2J10	SZPRL-04-B5	SZPT3-B8
SZPR25D□J10-06-A10		SZPB2J10	SZPRL-06-B5	
SZPR25D□J10-08-A10		SZPB2J10	SZPRL-08-B5	
SZPR25D□J20-04-A10	156.6	SZPB2J20	SZPRL-04-B5	
SZPR25D□J20-06-A10		SZPB2J20	SZPRL-06-B5	
SZPR25D□J20-08-A10		SZPB2J20	SZPRL-08-B5	
SZPR25D□J30-04-A10	146.6	SZPB2J30	SZPRL-04-B5	
SZPR25D□J30-06-A10		SZPB2J30	SZPRL-06-B5	
SZPR25D□J30-08-A10		SZPB2J30	SZPRL-08-B5	
SZPR25D□J40-04-A10	192.6	SZPB2J40	SZPRL-04-B5	
SZPR25D□J40-06-A10		SZPB2J40	SZPRL-06-B5	
SZPR25D□J40-08-A10		SZPB2J40	SZPRL-08-B5	
SZPR25D□J50-04-A10	202.6	SZPB2J50	SZPRL-04-B5	
SZPR25D□J50-06-A10		SZPB2J50	SZPRL-06-B5	
SZPR25D□J50-08-A10		SZPB2J50	SZPRL-08-B5	

## ◎ Flat Type (U) ○ Pads : 40, 50

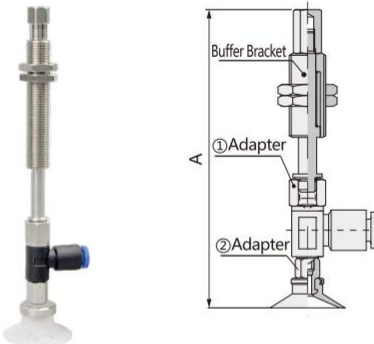

Model	○ Pads A		Buffer Bracket	①Adapter	②Adapter
	40	50			
SZPR○U□J10-06-A14	140.6	141.6	SZPB3J10	SZPRL-06-B8	SZPT4-B8
SZPR○U□J10-08-A14	140.6	141.6	SZPB3J10	SZPRL-08-B8	
SZPR○U□J20-06-A14	137.6	138.6	SZPB3J20	SZPRL-06-B8	
SZPR○U□J20-08-A14	137.6	138.6	SZPB3J20	SZPRL-08-B8	
SZPR○U□J30-06-A14	147.6	148.6	SZPB3J30	SZPRL-06-B8	
SZPR○U□J30-08-A14	147.6	148.6	SZPB3J30	SZPRL-08-B8	
SZPR○U□J50-06-A14	192.6	193.6	SZPB3J50	SZPRL-06-B8	
SZPR○U□J50-08-A14	192.6	193.6	SZPB3J50	SZPRL-08-B8	

## ◎ Flat Type with Ribs (C) ○ Pads : 40, 50

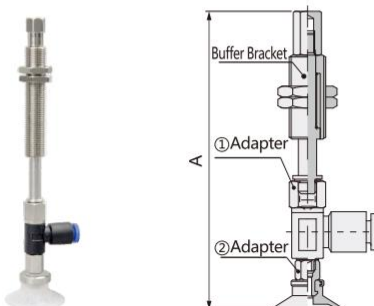

Model	○ Pads A		Buffer Bracket	①Adapter	②Adapter
	40	50			
SZPR○C□J10-06-A14	140.6	141.6	SZPB3J10	SZPRL-06-B8	SZPT4-B8
SZPR○C□J10-08-A14	140.6	141.6	SZPB3J10	SZPRL-08-B8	
SZPR○C□J20-06-A14	137.6	138.6	SZPB3J20	SZPRL-06-B8	
SZPR○C□J20-08-A14	137.6	138.6	SZPB3J20	SZPRL-08-B8	
SZPR○C□J30-06-A14	147.6	148.6	SZPB3J30	SZPRL-06-B8	
SZPR○C□J30-08-A14	147.6	148.6	SZPB3J30	SZPRL-08-B8	
SZPR○C□J50-06-A14	192.6	193.6	SZPB3J50	SZPRL-06-B8	
SZPR○C□J50-08-A14	192.6	193.6	SZPB3J50	SZPRL-08-B8	

# SZPR Series with Buffer



## ○ Bellows Type (B) ○ Pads : 40, 50

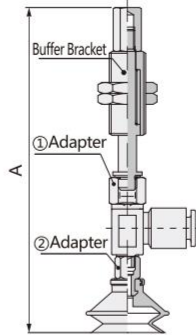

Model	○ Pads A		Buffer Bracket	①Adapter	②Adapter
	40	50			
SZPR○B□J10-06-A14	156.1	160.1	SZPB3J10	SZPRL-06-B8	SZPT4-B8
SZPR○B□J10-08-A14	156.1	160.1	SZPB3J10	SZPRL-08-B8	
SZPR○B□J20-06-A14	153.1	157.1	SZPB3J20	SZPRL-06-B8	
SZPR○B□J20-08-A14	153.1	157.1	SZPB3J20	SZPRL-08-B8	
SZPR○B□J30-06-A14	163.1	167.1	SZPB3J30	SZPRL-06-B8	
SZPR○B□J30-08-A14	163.1	167.1	SZPB3J30	SZPRL-08-B8	
SZPR○B□J50-06-A14	208.1	212.1	SZPB3J50	SZPRL-06-B8	
SZPR○B□J50-08-A14	208.1	212.1	SZPB3J50	SZPRL-08-B8	

## ○ Deep Type (D) ○ Pads : 40

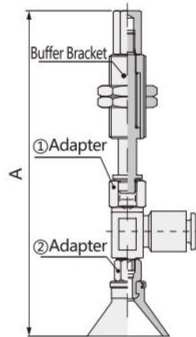

Model	○ Pads A		Buffer Bracket	①Adapter	②Adapter
	40	50			
SZPR40D□J10-06-A14	140.6	141.6	SZPB3J10	SZPRL-06-B8	ZPT4-B8
SZPR40D□J10-08-A14	140.6	141.6	SZPB3J10	SZPRL-08-B8	
SZPR40D□J20-06-A14	137.6	138.6	SZPB3J20	SZPRL-06-B8	
SZPR40D□J20-08-A14	137.6	138.6	SZPB3J20	SZPRL-08-B8	
SZPR40D□J30-06-A14	147.6	148.6	SZPB3J30	SZPRL-06-B8	
SZPR40D□J30-08-A14	147.6	148.6	SZPB3J30	SZPRL-08-B8	
SZPR40D□J50-06-A14	192.6	193.6	SZPB3J50	SZPRL-06-B8	
SZPR40D□J50-08-A14	192.6	193.6	SZPB3J50	SZPRL-08-B8	



SZPR