

SFM Series Compact Cylinder/Guide Rod Type

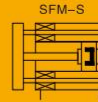

SFM

Guide Rod Type Cylinder

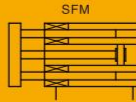

Specifications

Bore(mm)	20	25	32	40
Acting type	Double Acting			
Working medium	Clean Air(40 μ m filtration)			
Working pressure(MPa)	0.1~1.0			
Garanteed pressure(MPa)	1.5			
Working temperature(°C)	-20~70(No freezing)			
Speed range(mm/s)	30~500			
Stroke tolerance(mm)	+1,0 0			
Cushion type	Rubber cushion			
Port size	M5X0.8		G1/8	

● NPT、PT port size is optional.

How to Order?

Series	Bore	X	Stroke	-	Magnet	-	Thread Type
SFM	20 25 32 40		5 10 15 ...		Blank: No magnet S : With magnet		Blank: G P: PT T: NPT

Order Example:

SFM series basic cylinder, bore 25mm, stroke 20mm, with magnet, G thread, ERP code is: SFM25X20-S

Optional Accessories

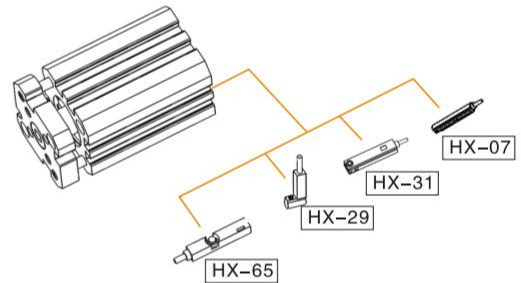

Note: Short stroke please use HX-29 series due to limited space.

Stroke

Bore (mm)	Standard Stroke (mm)																Max. Stroke (mm)		
Double Acting	20~40	5	10	15	20	25	30	35	40	45	50	55	60	70	75	80	90	100	100

Note: The dimensions of non-std stroke cylinder has the same dimensions as the next longer stroke std. stroke cylinder.
e.g. 27mm stroke cylinder has the same dimensions of 30 std. stroke cylinder.
When ordering stroke is larger than the maximum stroke, please contact us.

Internal Structure

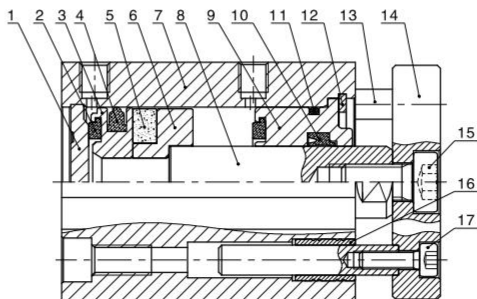

No.	Part Name	Material
1	Rear cover	Aluminum alloy
2	Anti-bump cushion	TPU
3	Piston	Aluminum alloy
4	Piston seal	NBR
5	Integrated magnet	RbFeB
6	Magnet base	Aluminum alloy
7	Barrel	Aluminum alloy
8	Piston rod	Stainless steel/Carbon steel
9	Head cover	Aluminum alloy
10	Piston rod seal	TPU
11	O-ring	NBR
12	C type retainer ring	Spring steel
13	Guide	Stainless steel
14	Fixing plate	Aluminum alloy
15	Hexagon Socket Cap Head Screw	Carbon steel
16	Slide bearing	Brass
17	Hexagon Socket Cap Head Screw	Carbon steel

Main Dimension

SFMΦ20、Φ25

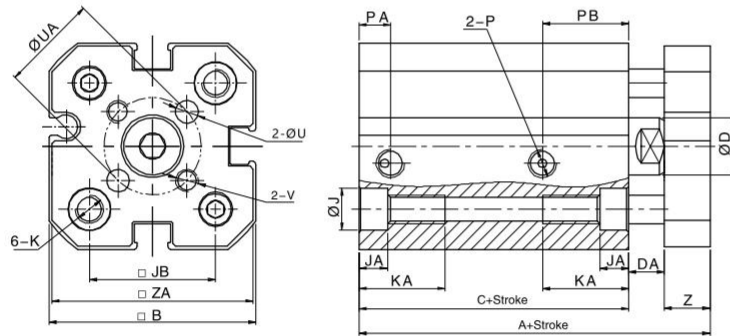

Bore/Sign	A	B	C	D	DA	J	JA	JB	K	KA	P	PA	PB	U	UA	V	Z	ZA
20	51	36	37	10	6	7.3	5	22	M5X0.8 Through holeΦ4.2	15	M5X0.8	5.5	15	4	17	M4X0.7	8	35
25	53	40	39	12	6	7.3	5	26	M5X0.8 Through holeΦ4.2	15	M5X0.8	5.5	17	5	22	M5X0.8	8	39

SFMΦ32、Φ40

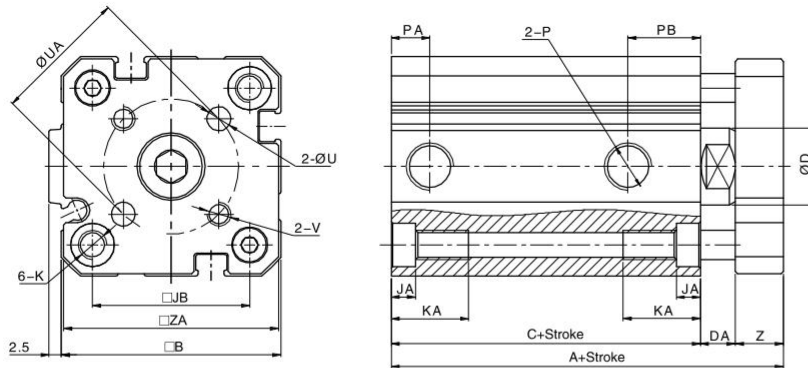

Bore/Sign	A	B	C	D	DA	J	JA	JB	K	KA	P	PA	PB	U	UA	V	Z	ZA
32	61	45.5	44	16	7	9	5	32.5	M6X1.0 Through holeΦ5.2	16	G1/8	8	15	5	28	M5X0.8	10	44.5
40	62.5	53	45	16	7.5	9	5	38	M6X1.0 Through holeΦ5.2	16	G1/8	9.5	16.5	5	33	M5X0.8	10	52