

EMQ Rotary Cylinder



Specifications

Specifications	7	10	20	30	50
Acting type	Double Cylinder, Rack & Pinion Style, Double Acting				
Working medium	Clean Air(40um filtration or better)				
Working pressure range	0.15~0.7MPa				
	None	0.15~0.7MPa			
Proof pressure(MPa)	1.5MPa				
Working temperature (°C)	-20~70(No freezing)				
Angle adjustable range	0~190°				
Repeat Accuracy	0.2°				
	None	0.05°			
Theoretical Torque(NM)(0.5Mpa)	0.63	1.1	2.2	2.8	5.0
Cushion	Rubber bumper(Standard)				
	None	Shock absorber(Optional)			
Port size	Front port	M5x0.8			G1/8
	Side port	M5x0.8			M5x0.8
Weight(g)	270	530	1020	1310	2130
	None	540	1020	1310	2140

Products Features

1. Rack and pinion structure for smooth operation.
2. Low backlash for excellent dynamic performance.
3. Dual-cylinder structure to achieve double the output force.
4. Special materials and heat treatment processes for the rack and pinion extend cylinder service life.
5. High machining accuracy of the worktable, with convenient load installation and precise positioning.
6. A through-hole in the center of the worktable allows for piping.
7. Positioning holes on both sides of the cylinder barrel for easy installation and use.
8. Two types of cushioning options: adjustable screw-fixed cushion and hydraulic cushion. The hydraulic cushion has 3 to 5 times the maximum cushioning capacity of the adjustable screw-fixed cushion, providing superior cushioning effect.

Note: When setting the rotation angle for rotary tables with shock absorbers, following the above table. Failing to follow the guide may result in a decrease in energy absorption capacity.

① PT、NPT port size is optional

Bore Size(mm)	10	20	30	50
Minimum rotation angle that will not allow decrease of energy absorption ability	61°	52°	46°	66°

4

EMQ

How to Order?

Series No	Specifications	Magnet No	Cushion Type	Thread Type
EMQ	7 10 20 30 50	S: With magnet (Magnet is standard)	A: With adjustment bolt R: With shock absorber (7 series no shock absorber is optional)	Blank: G P : PT T : NPT

Order Example:

EMQ Series Rotary Cylinder, Specifications 30, with adjustment bolt, G Thread, ERP code is: EMQ30-S-A
Note: Specific Bore and Stroke of the cylinder subject to the drawing.

Optional Accessories

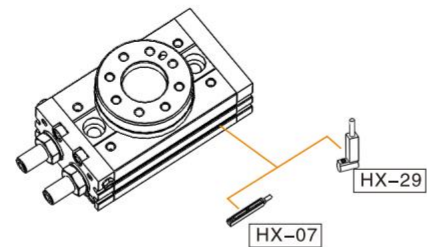

Note: Short stroke please use HX-29 series due to limited space.

Allowable Kinetic Energy and Rotation Time Adjustment Range

Model	Allowable kinetic energy (J)		Rotation time adjustment range for stable operation (s/90°)	
	With adjustment bolt	With shock absorber	With adjustment bolt	With shock absorber
EMQ7	0.006	None	0.2~1.0	None
EMQ10	0.01	0.04	0.2~1.0	0.2~0.7
EMQ20	0.025	0.12	0.2~1.0	0.2~0.7
EMQ30	0.05	0.12	0.2~1.0	0.2~0.7
EMQ50	0.08	0.30	0.2~1.0	0.2~0.7

- Note 1. If operated where the kinetic energy exceeds the allowable value, this may cause damage to the internal parts and result in product failure. Please pay special attention to the kinetic energy levels when designing and during operation to avoid exceeding the allowable limit.
2. When the rotation time of the type with an internal absorber is set longer than the time shown in the table above, energy absorption of the shock absorber greatly decreases.

Effective Output Torque

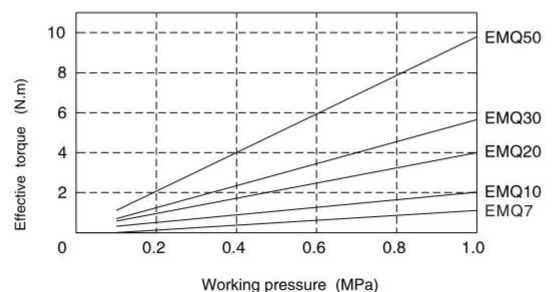

Installation and Use

1. Rotation direction and rotation angle

- 1.1 When pressurized from port A, the shaft rotates clockwise and counter-clockwise when pressurized from port B.
- 1.2 To obtain the desired rotation angle, the rotation ends can be set within the range shown in the diagram by regulating the adjustment bolt.
- 1.3 Rotary table with a shock absorber is available to adjust the rotation angle.

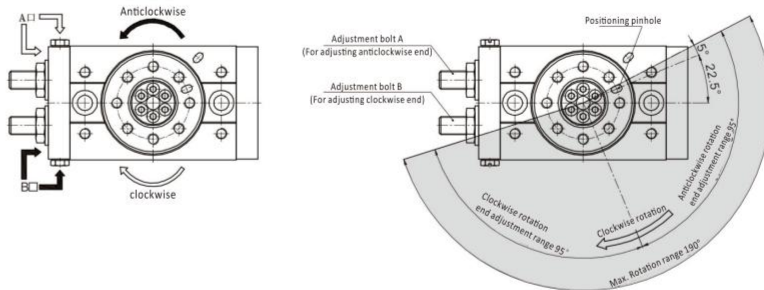

Note:

- * The figure above shows the rotation range of from the positioning pinhole.
- * Position of the pinhole in the figure above shows a counter-clockwise rotation where the rotation angle is set at 180° by equally tightening the A & B adjustment bolts.
- * The adjustment bolt of the shock absorber is factory set to the maximum output. Please adjust inward for first use if necessary.

2. Rotation range example:

- 2.1 Rotation can be set by adjusting the A & B adjuster bolts.
- 2.2 Rotary tables with shock absorbers can be set to various angles.

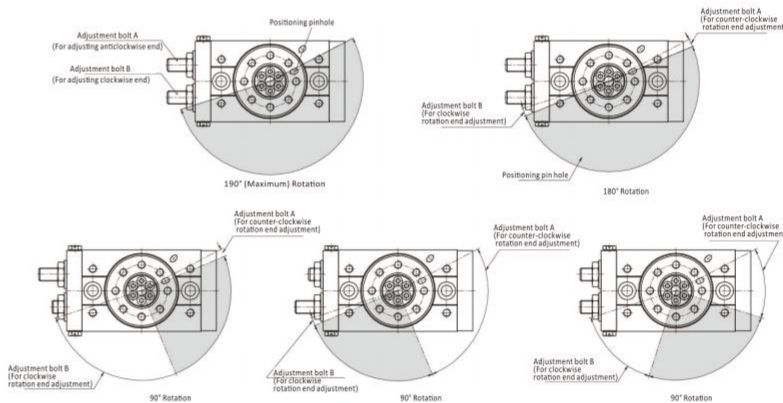

3. Adjustment angle per rotation (Adjustment bolt or shock absorber)

The adjustment angle of the turntable for each turn is as follows:

Bore size	Adjustment angle per rotation
7	10.2°
10	10.2°
20	7.4°
30	6.5°
50	8.2°

- 4. The rotation angle has been adjusted to the maximum output at the factory. Please do not extend the rotation angle beyond the maximum factory setting.
- 5. The movement energy should not exceed the maximum allowable energy, or the inner components can be damaged.
- 6. The rotary parts do not require lubrication.
- 7. Minimum operation pressure for a rotary table with a shock absorber is no less than 0.1Mpa.

8. Refer to the table below for tightening torques of the shock absorber setting nut.

Shock absorber size	Max. tightening torque (Nm)
M8X1.0	2.5
M10X1.0	3.5
M14X1.5	11

9. Never loosen the bottom screw of the shock absorber.

That may cause oil leakage.

10. Shock absorbers are consumable parts. When a decrease in energy absorption capacity is noticed, it must be replaced.

Series	Shock Absorber Type and Ordering code	Thread Type
EMQ10	AC0806-SN	M8X1.0
EMQ20	AC1007-SN	M10X1.0
EMQ30	AC1007-SN	M10X1.0
EMQ50	AC1412-SN	M14X1.5

11. Control the runout and parallelism of the dial according to the requirements of the following table:

Plane parallelism and runout of the dial

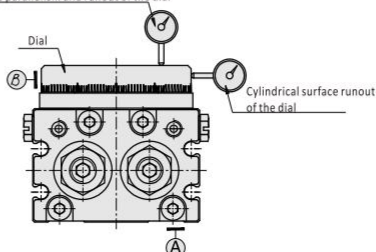

Items	Specific Requirements (mm)	Relative Datum
Plane parallelism of the dial	0.1	A
Plane runout of the dial	0.1	A
Cylindrical surface runout of the dial	0.1	B

Internal Structure

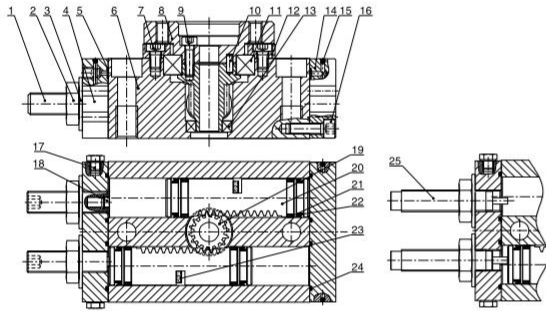

No.	Part Name	Material	No.	Part Name	Material
1	Adjustment screw	Carbon steel	14	Rear cover	Aluminum alloy
2	Hexagon nut	Carbon steel	15	Steel ball	Stainless steel
3	Seal washer	Carbon steel rubber coating	16	Hexagon socket head set screw	Carbon steel
4	Head cover	Aluminum alloy	17	Plug	Carbon steel
5	O-ring	NBR	18	Cushion pad	NBR
6	Barrel	Aluminum alloy	19	Pinion	Alloy steel
7	Hexagon socket head set screw	Carbon steel	20	Rack	Alloy steel
8	Dial	Aluminum alloy	21	Wear ring	PTFE
9	Hexagon socket head set screw	Carbon steel	22	Piston seal	NBR
10	Positioning pin	Stainless steel	23	Magnet	Sintered NdFeB
11	Deep groove ball bearing	Subassembly	24	O-ring	NBR
12	Plate	Aluminum alloy	25	Shock absorber	Subassembly
13	Deep groove ball bearing	Subassembly			

Main Dimension

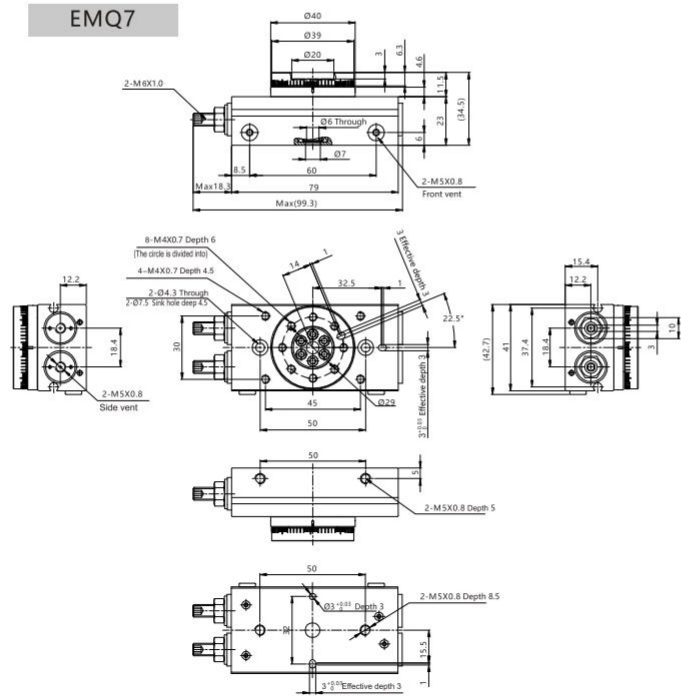

EMQ10~50

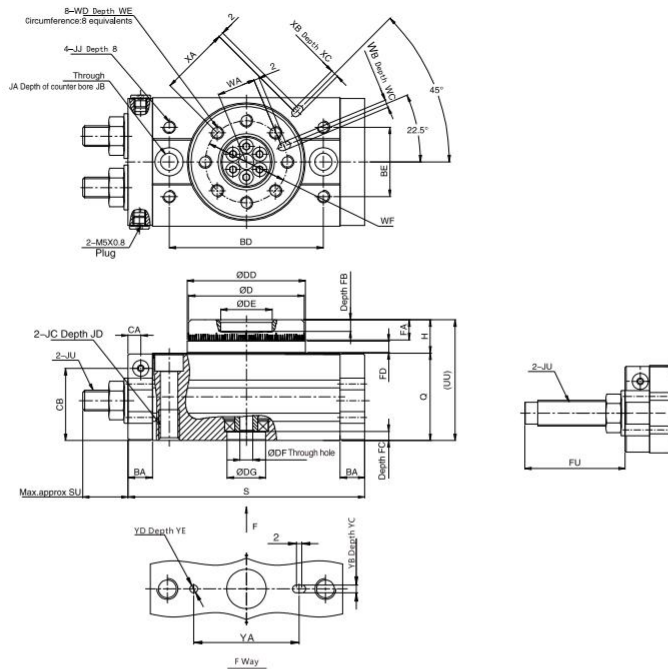

Model	AA	A	AV	AW	AY	BA	BB	BC	BD	BE	CA	CB	D	DD	DE	DF	DG	FA	FB	FC	FD	H	J	JA	JB	JC	FU
10	52.8	50	20	15.5	4	9.5	34.5	28	60	27	5	28	45 ^{+0.062} ₀	46 ^{+0.062} ₀	20 ^{+0.052} ₀	5	15 ^{+0.043} ₀	7.8	4.5	3.5	4.5	13	6.8	11	6.5	M8X1.25	30.9
20	67.8	65	27.5	16	5	12	47	30	76	34	6.5	30	60 ^{+0.074} ₀	61 ^{+0.074} ₀	28 ^{+0.052} ₀	9	17.4 ^{+0.043} ₀	9.8	6.5	3	6.5	17	8.6	14	8.5	M10X1.5	34.8
30	72.4	70	29	18.5	5	12	50	32.5	84	37	7	33.5	65 ^{+0.074} ₀	67 ^{+0.074} ₀	32 ^{+0.052} ₀	10	22 ^{+0.052} ₀	9.8	5	3.5	6.5	17	8.6	14	8.5	M10X1.5	34.8
50	82.4	80	38	22	6	15.5	63	37.5	100	50	10	37.5	75 ^{+0.074} ₀	77 ^{+0.074} ₀	35 ^{+0.052} ₀	11	28 ^{+0.052} ₀	11.8	5.5	3.5	7.5	20	10.3	18	10.5	M12X1.75	54.3
Model	JD	JJ	JU	P	Q	S	SD	SE	SF	SU	UU	WA	WB	WC	WD	WE	WF	XA	XB	XC	YA	YB	YC	YD	YE		
10	12	M5X0.8	M8X1	M5X0.8	34	92	9	13	45	17.3	47	15	3 ^{+0.025} ₀	3.5	M5X0.8	8	32	27	3 ^{+0.03} ₀	3.5	40	3 ^{+0.03} ₀	3.5	03 ^{+0.03} ₀	3.5		
20	15	M6X1	M10X1	M5X0.8	37	117	10	12	59.7	24.8	54	20.5	4 ^{+0.03} ₀	4.5	M6X1	10	43	36	4 ^{+0.03} ₀	4.5	50	4 ^{+0.03} ₀	4.5	04 ^{+0.03} ₀	4.5		
30	15	M6X1	M10X1	1/8"	40	127	11.5	14	64.7	24.8	57	23	4 ^{+0.03} ₀	4.5	M6X1	10	48	39	4 ^{+0.03} ₀	4.5	58	4 ^{+0.03} ₀	4.5	04 ^{+0.03} ₀	4.5		
50	18	M8X1.25	M14X1.5	1/8"	46	152	14.5	15	74.7	31.3	66	26.5	5 ^{+0.03} ₀	5.5	M8X1.25	12	55	45	5 ^{+0.03} ₀	5.5	68	5 ^{+0.03} ₀	5.5	05 ^{+0.03} ₀	5.5		