

ELQ/ELQL Series Slide Cylinder



ELQ/ELQL

Slide Cylinder

ELQ/ELQL Series Slide Cylinder(with magnet,rubber cushion)

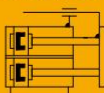

Specifications

Bore(mm)	6	8	12	16	20	25
Acting Type	Double Acting					
Working Medium	Clean Air(after 40 μm filtration)					
Working Pressure(MPa)	0.15-0.7					
Guaranteed Pressure(MPa)	1.05					
Working Temperature(°C)	-20-70(No freezing)					
Piston Speed(mm/s)	50-500					
Stroke tolerance	Stroke ≤ 100 ^{+1.0} ₀ Stroke > 100 ^{+1.5} ₀					
Cushion	Rubber cushion on both ends、Shock absorber cushion					
Port Size	M5x0.8			G1/8		

How to order?

Optional Accessories

Series No.	Bore X Stroke	Magnet No.	Adjuster	Thread Type
ELQ:Standard Type ELQL:Symmetric Type	6 8 12 16 20 25	S: With magnet Blank: None	Blank: None adjuster A: Adjusters on both ends AS: Forward adjuster AF: Backward adjuster B: Shock absorber on both ends BS: Forward shock absorber BF: Backward shock absorber (Note: Shock absorber is not available for φ6)	Blank: G

Order Example:

ELQ Series Basic type cylinder, bore size 20, stroke 50, with Magnet, without adjuster, thread type G.The ERP code is: ELQ20X50-S

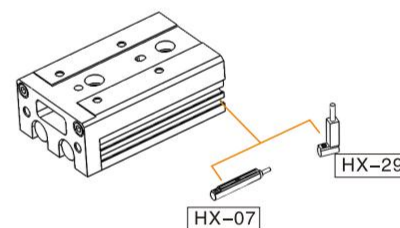

Note:Short stroke please use HX-29 series due to limited space.

Stroke

Bore(mm)	Standard Stroke(mm)								Max.Stroke(mm)
	10	20	30	40	50	75	100	125	
Double Acting	6	10	20	30	40	50			50
	8	10	20	30	40	50	75		75
	12	10	20	30	40	50	75	100	100
	16	10	20	30	40	50	75	100	125
	20	10	20	30	40	50	75	100	125
25	10	20	30	40	50	75	100	125	150

Weight(g)

Bore(mm)	Stroke(mm)							
	10	20	30	40	50	75	100	125
6	73	90	103	131	149	—	—	—
8	129	151	175	211	261	—	—	—
12	303	307	354	412	461	614	—	—
16	505	514	558	622	713	889	1104	1266
20	912	923	934	1042	1155	1475	1906	2098
25	1402	1420	1438	1562	1782	2123	2571	3053

Note: The weight in the above table is the standard product weight without adjuster.

Internal Structure

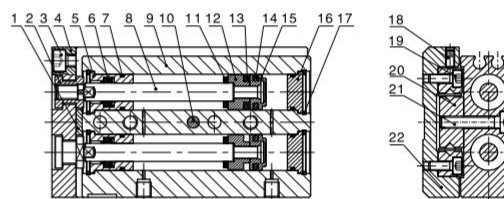

No.	Part Name	Material
1	Cushion Pad	TPU
2	Fixing Screw	Stainless Steel
3	Hexagon Socket Cap Head Screw	Carbon Steel
4	Fixing Plate	Aluminum Alloy
5	Front Cover	Aluminum Alloy
6	Front Scraper Seal	NBR
7	O-ring	NBR
8	Piston Rod	Stainless Steel
9	Barrel	Aluminum Alloy
10	Positioning pin	Stainless Steel
11	Anti-Crash Gasket	TPU
12	Magnet Seat	Aluminum Alloy
13	Integrated Magnet	RbFeB
14	Piston Seal	NBR
15	Piston	Aluminum Alloy
16	Rear Cover	Aluminum Alloy
17	C-Type Retainer Ring	Spring Steel
18	Hexagon Socket Set Screw	Carbon Steel
19	Hexagon Socket Cap Head Screw	Carbon Steel
20	Linear Roller Sliding Guide Rail	Assembly
21	Hexagon Socket Cap Head Screw	Carbon Steel
22	Slide Table	Aluminum Alloy

4
ELQ/ELQL

Model Selection Method

Please select compact cylinder's type according to following procedure, and cross reference with data sheets.

1. Operating conditions (According to mounting position and work form)

- 1.1 Model used (Bore size, Stroke)
- 1.2 Type of cushion (Bumper, Shock absorber)
- 1.3 Mounting position of work (Top, front)
- 1.4 Mounting direction (Axial, Vertical)
- 1.5 Average speed V_a (mm/s)
- 1.6 Applied load W (N) **Fig. 1**
- 1.7 Overhang L_1, L_2, L_3 (mm)

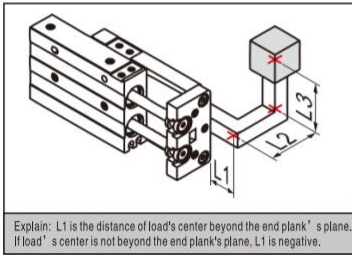
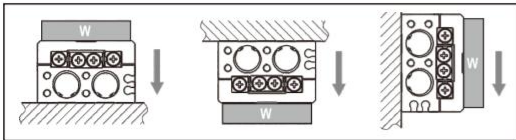

Fig. 1 Applied load



3. Load Check

Detailed procedures

3.1 Calculate allowable applied load W_a (N)

$$W_a = K \times \beta \times W_{max}$$

K : Mounting work coefficient (Fig 2) W_{max} : Maximum allowable applied load (Table 1)
 β : Applied load coefficient (Fig 3)

3.2 Check that load (W) doesn't exceed allowable applied load (W_a)

$$W \leq W_a$$

Fig. 2 Mounting work coefficient (K)

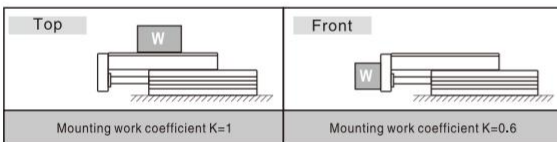
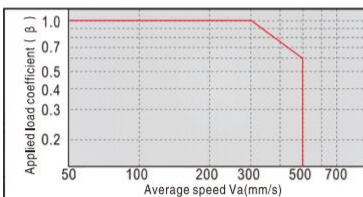

Fig. 3 Applied load coefficient (β)



2. Kinetic energy check

Detailed procedures

2.1 Calculate kinetic energy of load E (J)

$$E = \frac{1}{2} \times \frac{W}{g} \times \left(\frac{1.4 \times V_a}{1000} \right)^2$$

2.2 Calculate allowable kinetic energy E_a (J)

$$E_a = K \times E_{max}$$

K : Mounting work coefficient (Fig 2) E_{max} : Maximum allowable kinetic energy (Table 1)

2.3 Check that kinetic energy of load doesn't exceed allowable kinetic energy

$$E \leq E_a$$

4. Moment check

Detailed procedures

Horizontal

* Calculate actual moment: $M_p, M_{p0}, M_y, M_{y0}, M_r, M_{r0}$ (Nm)

Moment Type	Dynamic Moment	Static Moment
M_p, M_{p0}	$M_p = W \times (L_1 + A) / 1000$	$M_{p0} = \frac{W \times (L_1 + A)}{1000} + \frac{W \times a \times (L_2 + B)}{1000 \times g}$
M_r, M_{r0}	$M_r = W \times (C + L_3) / 1000$	$M_{r0} = \frac{W \times (L_1 + A)}{1000} + \frac{W \times a \times (L_2 + B)}{1000 \times g}$
M_y, M_{y0}	$M_y = 0$	$M_{y0} = (W \times a \times (C + L_3)) / 1000g$

* Check

Dynamic moment:	$\frac{M_p}{M_{p_{max}}} + \frac{M_y}{M_{y_{max}}} + \frac{M_r}{M_{r_{max}}} \leq 1$
Static moment:	$\frac{M_{p0}}{M_{p0_{max}}} + \frac{M_{y0}}{M_{y0_{max}}} + \frac{M_{r0}}{M_{r0_{max}}} \leq 1$

Vertical

* Calculate actual moment: $M_p, M_{p0}, M_y, M_{y0}, M_r, M_{r0}$ (Nm)

Moment Type	Dynamic Moment	Static Moment
M_p, M_{p0}	$M_p = W \times (L_2 + B) / 1000$	$M_{p0} = \frac{W \times (L_2 + B)}{1000} + \frac{W \times a \times (L_2 + B)}{1000 \times g}$
M_y, M_{y0}	$M_y = W \times (C + L_3) / 1000$	$M_{y0} = \frac{W \times a \times (C + L_3)}{1000g} + \frac{W \times (C + L_3)}{1000}$

*** Check**

Dynamic moment:	$\frac{M_p}{M_{p_{max}}} + \frac{M_y}{M_{y_{max}}} \leq 1$
Static moment:	$\frac{M_{p0}}{M_{p0_{max}}} + \frac{M_{y0}}{M_{y0_{max}}} \leq 1$

Explain:
 The distance of load center to mount plane (Determined by actuality).
 A, B, C: Correction value for center position distance of moment (Refer to table 2).
 $M_{p_{max}}, M_{y_{max}}, M_{r_{max}}, M_{p0_{max}}, M_{y0_{max}}, M_{r0_{max}}$: Maximum allowable moment (Refer to table 2);
 g : Acceleration of gravity ($g = 9.81 \text{ m/s}^2$).
 a : Acceleration of inertia
 $a = 1600 \times (V_a / 1000)^2$; Shock absorber
 $a = 400 \times (V_a / 1000)^2$
 W : Load weight (Determined by actuality).

ELQ/ELQL Series Slide Cylinder



Model Selection Method

Please select compact cylinder's type according to following procedure, and cross reference with data sheets.

Note: Symbol and unit

Symbol	Item	Unit
A,B,C	Correction value for center position distance of moment	mm
a	Acceleration of inertia	-
E	Kinetic energy	J
Ea	Allowable kinetic energy	J
E _{max}	Maximum allowable kinetic energy	J
g	Acceleration of gravity g=9.81	m/s
K	Mounting work coefficient	-
L1,L2,L3	Overhang	mm
Mp,My,Mr	Dynamic moment(Pitch Yaw Roll)	Nm
Mp _{max} ,My _{max} ,Mr _{max}	Maximum allowable dynamic moment(Pitch Yaw Roll)	Nm
Mpo,Myo,Mro	Static moment(Pitch Yaw Roll)	Nm
Mpo _{max} ,Myo _{max} ,Mro _{max}	Maximum allowable static moment(Pitch Yaw Roll)	Nm
Va	Average speed	m/s
W	Applied load	N
W _{max}	Maximum allowable applied load	N
β	Applied load coefficient	-

Table 1: Maximum allowable kinetic energy(E_{max})Maximum allowable applied load(W_{max})

Model	Maximum allowable kinetic energy E _{max} (J)			Maximum allowable applied load W _{max} (N)
	Basic type	Rubber stopper type	Shock absorber type	
ELQ6	0.01	0.01	-	4
ELQ8	0.024	0.024	0.048	8
ELQ12	0.05	0.05	0.1	15
ELQ16	0.1	0.1	0.2	30
ELQ20	0.13	0.13	0.26	40
ELQ25	0.22	0.22	0.44	70

Table 2: Maximum allowable moment(Nm), Correction value for center position distance of moment(mm)

Bore size	Stroke	Static moment			Dynamic moment			Correction value		
		Mpo _{max}	Myo _{max}	Mro _{max}	Mp _{max}	My _{max}	Mr _{max}	A	B	C
ELQ6	10	3.3	3.8	2.6	0.7	0.7	0.6	27	7.3	15
	20	3.3	3.8	2.6	0.7	0.8	0.6	42		
	30	3.3	3.8	2.6	0.7	0.8	0.6	52		
	40	7.2	7.9	3.6	1.3	1.3	0.6	72		
	50	12.4	12.7	4.7	1.8	1.8	0.6	87		
ELQ8	10	10.1	9.1	8.8	2.5	2.5	2.0	32	8.5	19
	20	10.1	9.1	8.8	2.6	2.6	2.0	42		
	30	10.1	9.1	8.8	2.8	2.8	2.0	57		
	40	12.4	10.8	10.1	3.4	3.4	2.3	72		
	50	23.6	24.8	13.9	4.4	4.4	2.1	92		
ELQ12	10	33	34.3	30.9	7.3	7.3	5.8	48	10	25
	20	33	34.3	30.9	7.6	7.6	5.8	58		
	30	33	34.3	30.9	7.8	7.8	5.8	68		
	40	33	34.3	30.9	8.0	8.0	5.8	78		
	50	53.4	49.6	39.7	9.8	9.8	5.8	88		
ELQ16	10	33	34.3	30.9	8.8	8.8	7.6	43	11	30
	20	33	34.3	30.9	9.2	9.2	7.6	53		
	30	33	34.3	30.9	9.5	9.5	7.6	63		
	40	33	34.3	30.9	10.0	10.0	7.6	78		
	50	53.4	49.6	39.7	12.2	12.2	7.6	93		
ELQ20	10	60.1	50.5	72.8	14.5	14.5	15.2	47	16.5	35
	20	60.1	50.5	72.8	15.2	15.2	15.2	57		
	30	60.1	50.5	72.8	15.7	15.7	15.2	67		
	40	60.1	50.5	72.8	16.3	16.3	15.2	82		
	50	60.1	50.5	72.8	16.6	16.6	15.2	92		
ELQ25	10	60.1	50.5	72.8	16.3	16.3	17.6	52	20.3	42
	20	60.1	50.5	72.8	17.0	17.0	17.6	62		
	30	60.1	50.5	72.8	17.4	17.4	17.6	72		
	40	60.1	50.5	72.8	17.8	17.8	17.6	82		
	50	60.1	50.5	72.8	18.2	18.2	17.6	96		
ELQ25	75	169.3	154.3	114.4	45.2	45.2	25.3	141	20.3	42
	100	169.3	154.3	114.4	46.2	46.2	25.3	165		
	125	169.3	154.3	114.4	43.6	43.6	22.0	205		
	150	267.5	286.6	145.6	49.0	49.0	20.5	249		
	150	267.5	286.6	145.6	65.0	65.0	28.3	254		

ELQ/ELQL 4

Installation and Operation

1. How to mount cylinder:

1.1 Cylinder can be mounted from 3 directions.

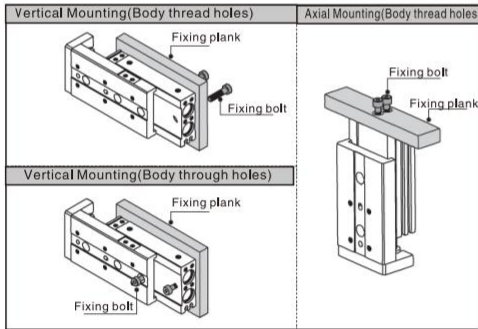

1.2 When mounting an compact slide cylinder, screws of appropriate length should be used and tightened properly within the maximum tightening torque. If screws are tightened beyond designed limits, malfunction may occur. If they are tightened insufficiently, it may result in sliding of falling off from its position.

Vertical Mounting(Body thread holes)	Model	Bolt used	Max.tightening torque (Nm)	Max.screw-in depth l(mm)
	ELQ6	M4X0.7	2.1	8
	ELQ8	M4X0.7	2.1	8
	ELQ12	M5X0.8	4.4	10
	ELQ16	M6X1.0	7.4	12
	ELQ20	M6X1.0	7.4	12
ELQ25	M8X1.25	18	16	
Vertical Mounting(Body through holes)	Model	Bolt used	Max.tightening torque (Nm)	Max.screw-in depth l(mm)
	ELQ6	M3X0.5	1.2	10.8
	ELQ8	M3X0.5	1.2	12
	ELQ12	M4X0.7	2.8	13.5
	ELQ16	M5X0.8	5.7	16.5
	ELQ20	M5X0.8	5.7	22
ELQ25	M6X1.0	10	28	
Axial Mounting(Body through holes)	Model	Bolt used	Max.tightening torque (Nm)	Max.screw-in depth l(mm)
	ELQ6	M2.5X0.45	0.5	3.5
	ELQ8	M3X0.5	0.9	4.0
	ELQ12	M4X0.7	2.1	6.0
	ELQ16	M5X0.8	4.4	7.0
	ELQ20	M5X0.8	4.4	8.0
ELQ25	M6X1.0	7.4	10.0	

2. Work Piece Mounting:

2.1 Work pieces can be mounted on 2 surfaces of the compact slide.

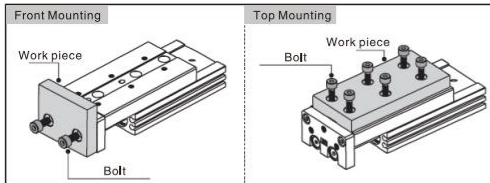

2.2 When mounting a work piece, tighten the bolts properly at a torque value within the limiting range. Use bolts at least 0.5mm shorter than maximum thread depth to prevent bolts from contacting the guide block. If the bolts are too long, they hit the guide block and cause damage.

Front Mounting	Model	Bolt used	Max.tightening torque (Nm)	Max.screw-in depth l(mm)
	ELQ6	M3X0.5	0.9	5
	ELQ8	M4X0.7	2.1	6
	ELQ12	M5X0.8	4.4	8
	ELQ16	M6X1.0	7.4	10
	ELQ20	M6X1.0	7.4	13
ELQ25	M8X1.25	18	15	
Top Mounting	Model	Bolt used	Max.tightening torque (Nm)	Max.screw-in depth l(mm)
	ELQ6	M3X0.5	0.9	4
	ELQ8	M3X0.5	0.9	4.5
	ELQ12	M4X0.7	2.1	5.5
	ELQ16	M5X0.8	4.4	7.5
	ELQ20	M5X0.8	4.4	9.5
ELQ25	M6X1.0	7.4	13	

2.3 Since the table is supported by the linear guide, take care not to apply strong impact or large moment to the guide section.

2.4 Hold the slide when fastening work pieces to it with bolts, if the body is held while tightening bolts, excessive moment may damage guide section.

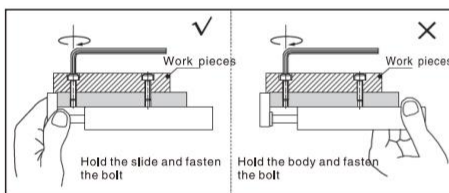

3. About shock absorber:

3.1 Shock absorbers are expendable parts. Promptly replace them when energy absorbing capacity decreases.

3.2 Never turn or adjust the screws on bottom of the shock absorber body. The screws are not for adjusting. Otherwise would cause oil leakage.

3.3 Follow the table for tightening torque of shock absorber to lock nuts.

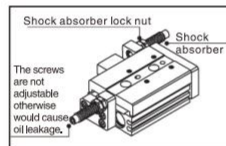

Model	Shock absorber	Tightening torque (Nm)
ELQ8	AC0806-WY	1.67
ELQ12	AC0806-WY	1.67
ELQ16	AC1008-WY	3.14
ELQ20	AC1416-WY	10.8
ELQ25	AC1416-WY	10.8

4. How to mount sensor switch:

4.1 ELQ Series are all with magnet.

4.2 Maintain a minimum spacing of at least 3mm if two compact cylinders are used side by side in order to avoid malfunction.

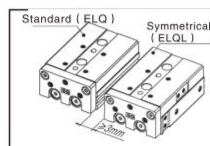

5. Make sure to connect the compact cylinder to speed controller at the meter-out side, and the speed of compact cylinder must be below 500mm/s.

ELQ/ELQL Series Slide Cylinder



Main Dimensions

ELQ 6

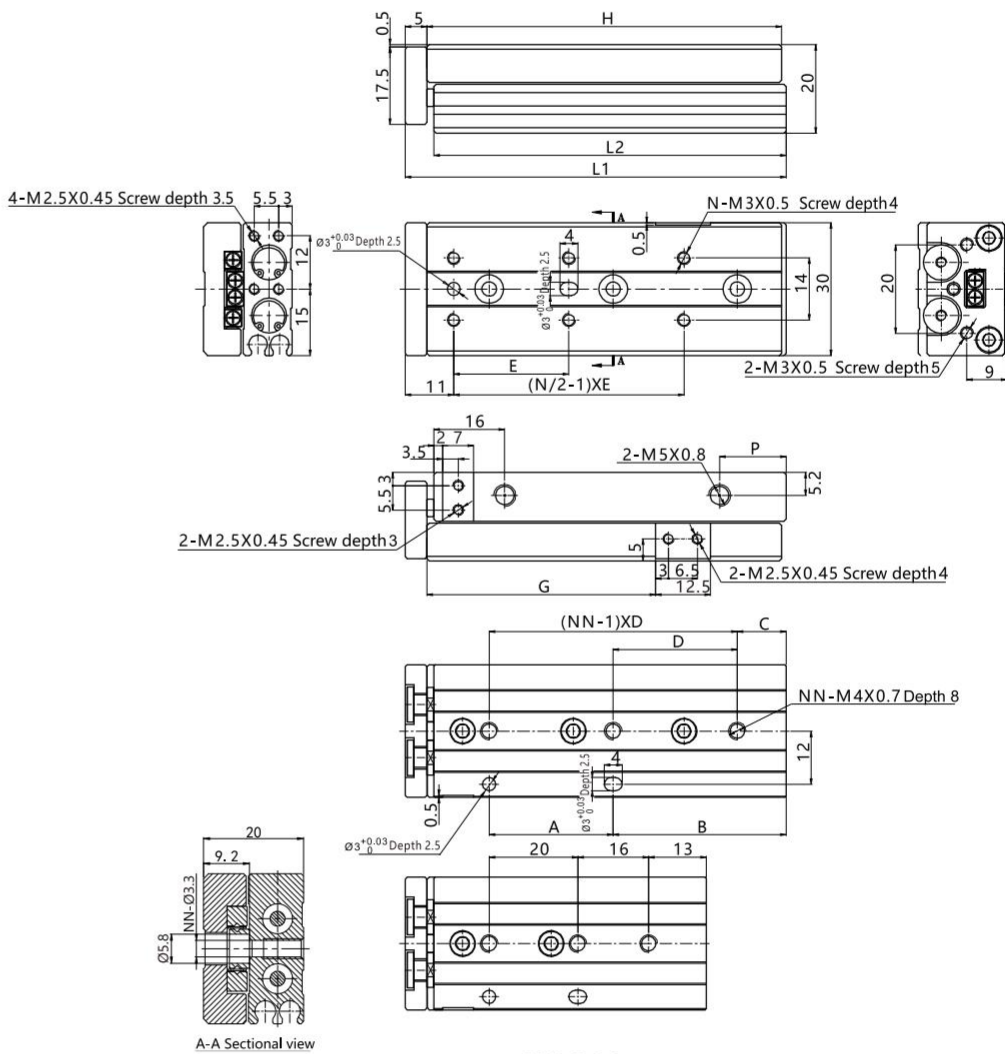

ELQ 6x30

Stroke/Sign	A	B	C	D	E	G	H	P	L1	L2	N	NN
10	16	13	6	23	22	21.5	42	9.5	48	41.5	4	2
20	26	13	13	26	25	31.5	52	9	58	51.5	4	2
30	20	29	See drawing	See drawing	21	41.5	62	9	68	61.5	6	3
40	28	39	11	28	26	51.5	80	15	86	79.5	6	3
50	28	49	21	28	27	61.5	90	15	96	89.5	6	3

4
ELQ/ELQL

Main Dimensions

ELQL 6

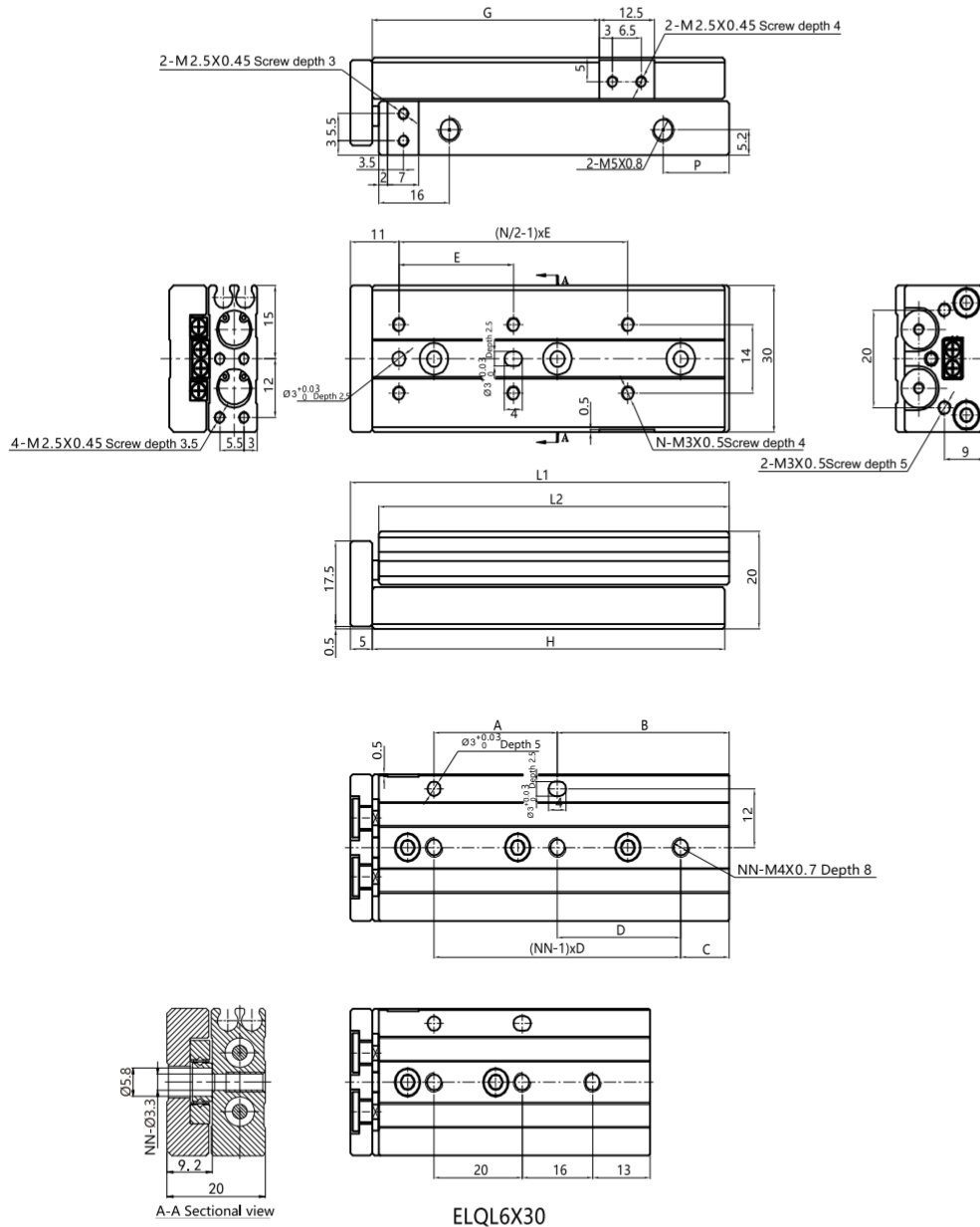

Storke/Sign	A	B	C	D	E	G	H	P	L1	L2	N	NN
10	16	13	6	23	22	21.5	42	9.5	48	41.5	4	2
20	26	13	13	26	25	31.5	52	9	58	51.5	4	2
30	20	29	See drawing	See drawing	21	41.5	62	9	68	61.5	6	3
40	28	39	11	28	26	51.5	80	15	86	79.5	6	3
50	28	49	21	28	27	61.5	90	15	96	89.5	6	3

ELQ/ELQL Series Slide Cylinder



Main Dimensions

ELQ 8

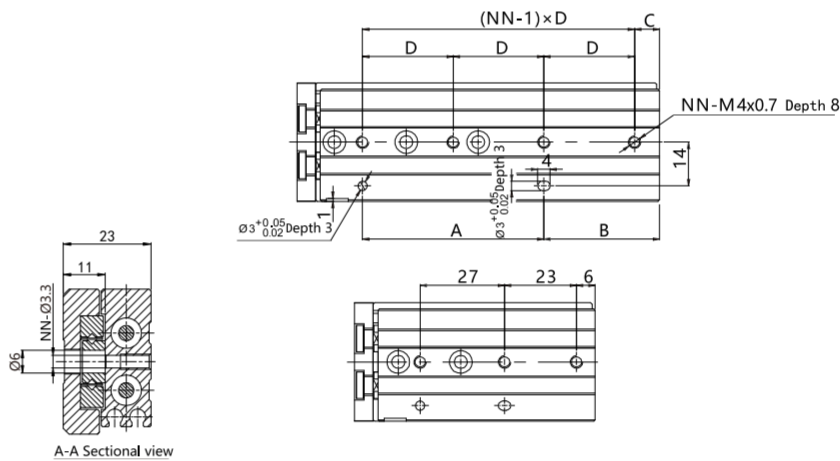
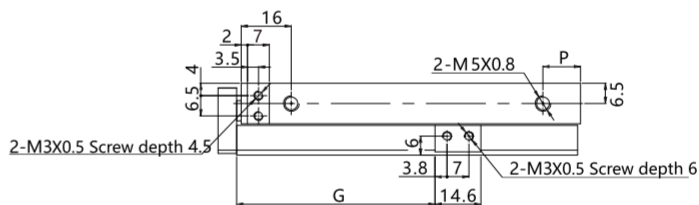
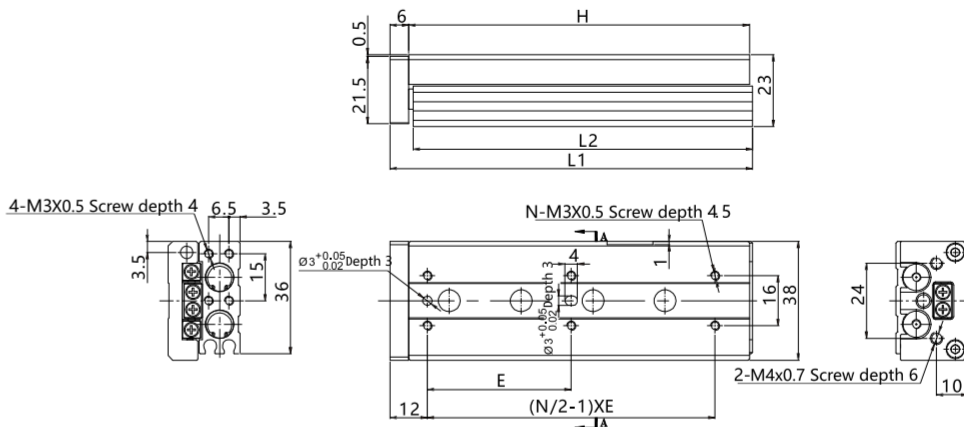

ELQ 8x30

Stroke/Sign	A	B	C	D	E	G	H	P	L1	L2	N	NN
10	19	13	7	25	25	23.5	46	10.5	53	45.5	4	2
20	28	14	14	28	25	33.5	56	10	63	55.5	4	2
30	27	29	See drawing	See drawing	26	43.5	70	10	77	69.5	6	3
40	31	39	8	31	32	53.5	84	12	91	83.5	6	3
50	58	37	8	29	46	63.5	109	12	116	108.5	6	4
75	60	63	33	30	50	88.5	137	10	144	136.5	6	4

4
ELQ/ELQL

Main Dimensions

ELQL 8

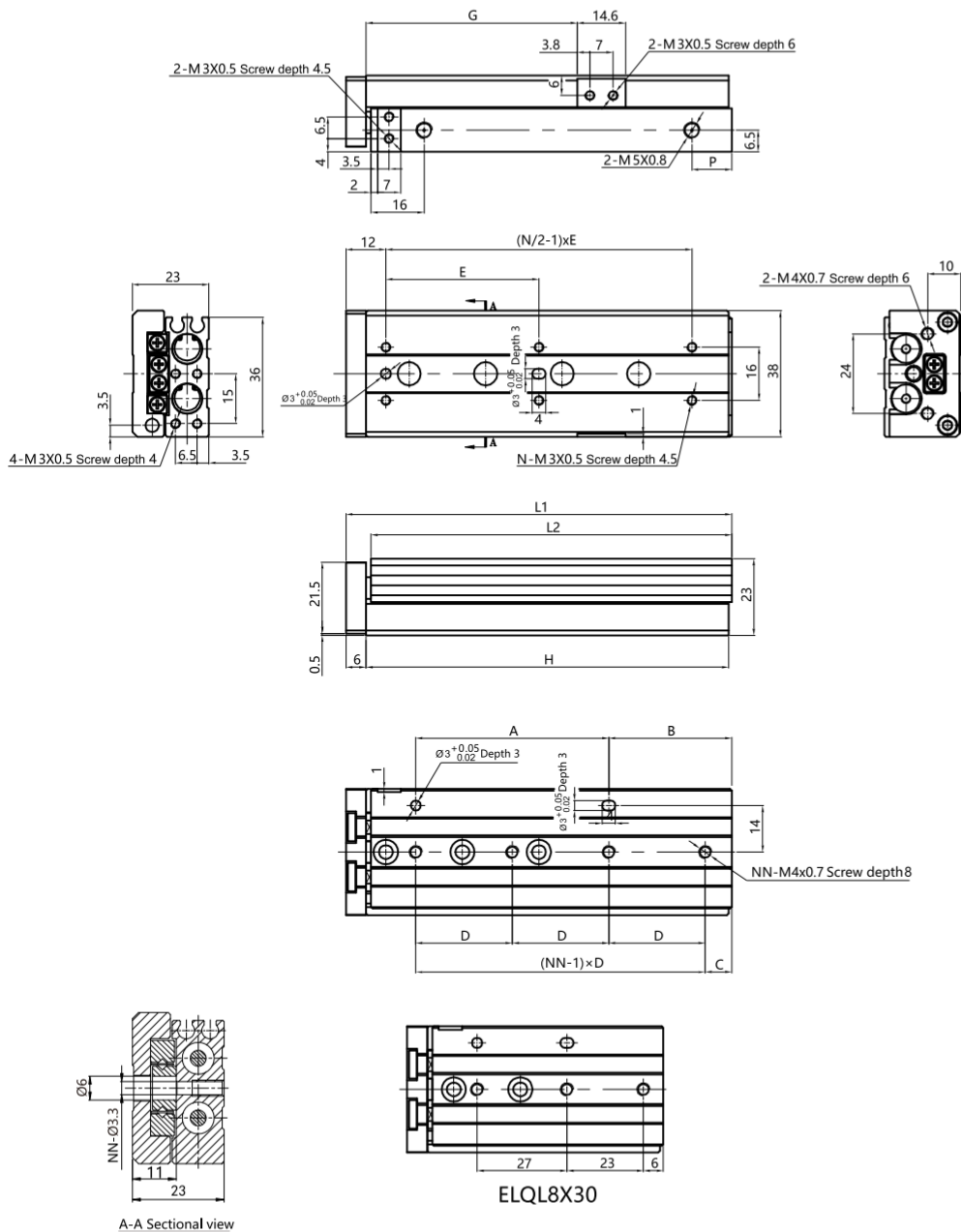

Storke/Sign	A	B	C	D	E	G	H	P	L1	L2	N	NN
10	19	13	7	25	25	23.5	46	10.5	53	45.5	4	2
20	28	14	14	28	25	33.5	56	10	63	55.5	4	2
30	27	29	See drawing	See drawing	26	43.5	70	10	77	69.5	6	3
40	31	39	8	31	32	53.5	84	12	91	83.5	6	3
50	58	37	8	29	46	63.5	109	12	116	108.5	6	4
75	60	63	33	30	50	88.5	137	10	144	136.5	6	4

ELQ/ELQL Series Slide Cylinder



◎ Main Dimensions

ELQ 12

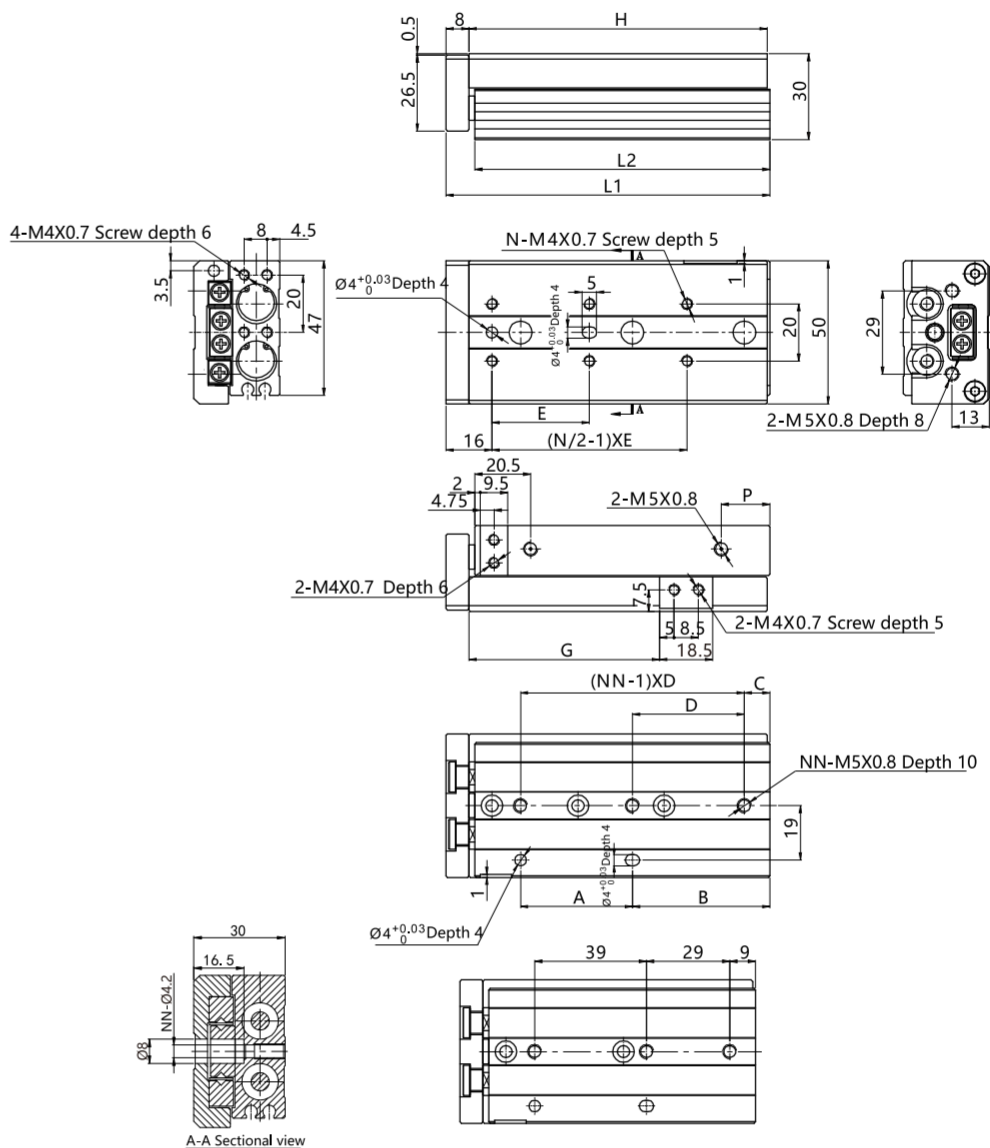

ELQ12x40

Stroke/Sign	A	B	C	D	E	G	H	L1	L2	N	NN
10	32	18	18	32	28	26.5	67	76	66	4	2
20	32	18	18	32	28	36.5	67	76	66	4	2
30	40	20	20	40	38	46.5	77	86	76	4	2
40	39	38	See drawing	See drawing	34	56.5	94	103	93	6	3
50	39	48	9	39	34	66.5	104	113	103	6	3
75	72	59	23	36	36	91.5	148	157	147	8	4
100	72	84	12	36	36	116.5	173	182	172	10	5

ELQ/ELQL 4

ELQ/ELQL Series Slide Cylinder



Main Dimensions

ELQ 20

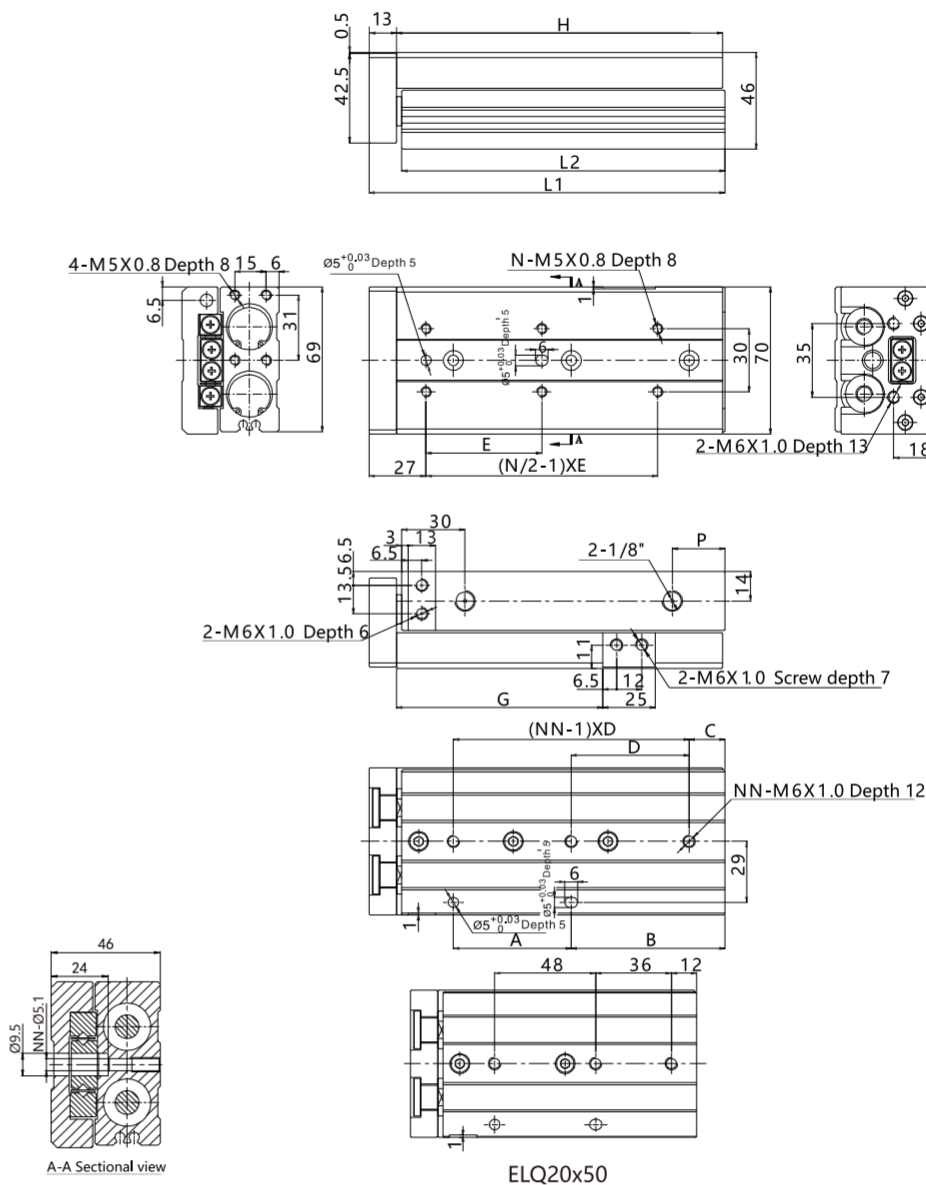

Stroke/Sign	A	B	C	D	E	P	G	H	L1	L2	N	NN
10	50	18	22	46	45	16	31	94	108	92.5	4	2
20	50	18	22	46	40	16	41	94	108	92.5	4	2
30	50	18	22	46	48	16	51	94	108	92.5	4	2
40	56	22	22	56	58	16	61	104	118	102.5	4	2
50	48	48	See drawing	See drawing	42	18	71	122	136	120.5	6	3
75	56	73	17	56	55	25	96	155	169	153.5	6	3
100	112	74	18	56	50	25	121	212	226	210.5	8	4
125	118	96	37	59	55	25	146	240	254	238.5	8	4
150	124	118	56	62	62	25	171	268	282	266.5	8	4

4
ELQ/ELQL

Main Dimensions

ELQL 20

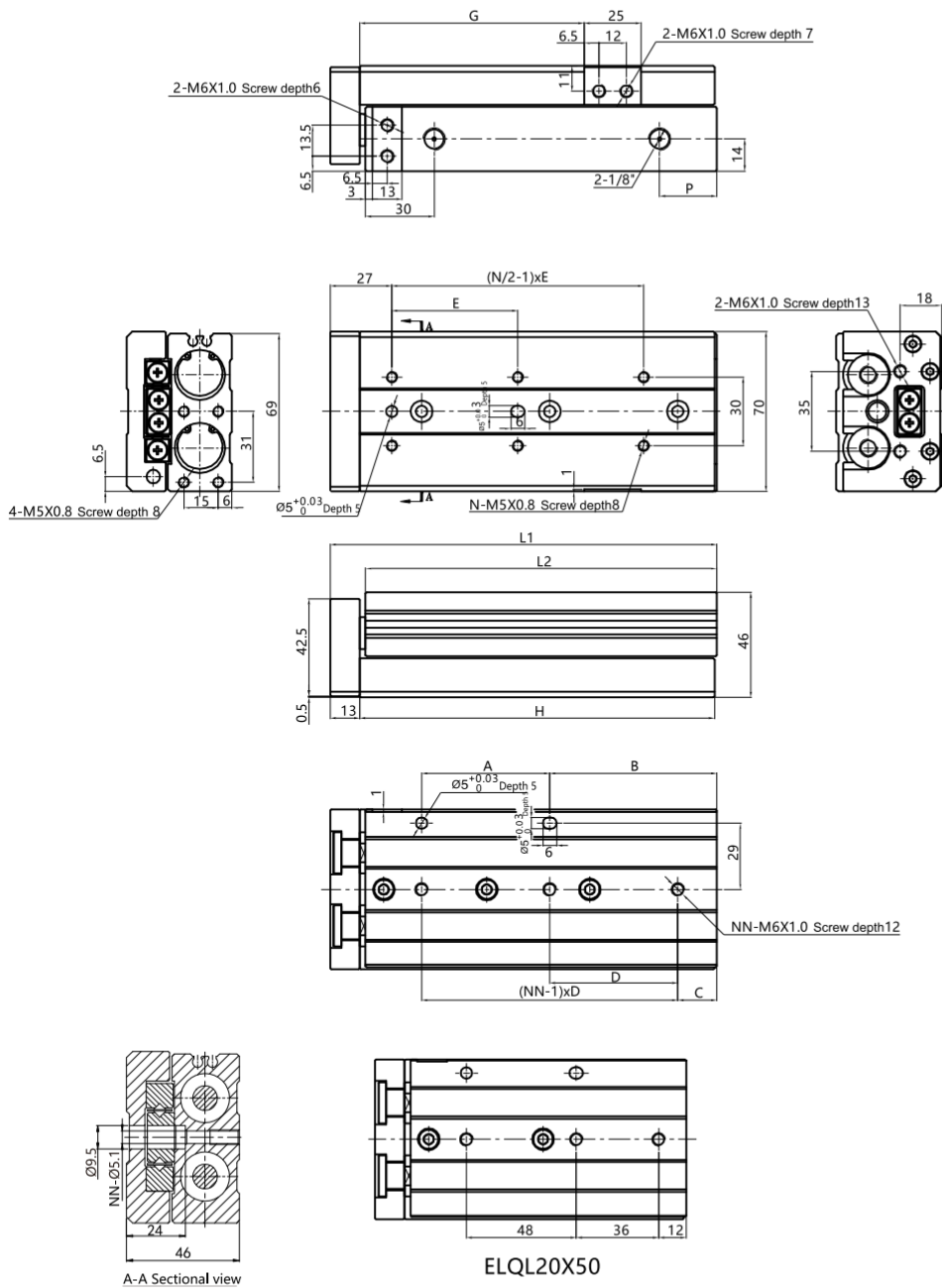

Storke/Sign	A	B	C	D	E	P	G	H	L1	L2	N	NN
10	50	18	22	46	45	16	31	94	108	92.5	4	2
20	50	18	22	46	40	16	41	94	108	92.5	4	2
30	50	18	22	46	48	16	51	94	108	92.5	4	2
40	56	22	22	56	58	16	61	104	118	102.5	4	2
50	48	48	See drawing	See drawing	42	18	71	122	136	120.5	6	3
75	56	73	17	56	55	25	96	155	169	153.5	6	3
100	112	74	18	56	50	25	121	212	226	210.5	8	4
125	118	96	37	59	55	25	146	240	254	238.5	8	4
150	124	118	56	62	62	25	171	268	282	266.5	8	4

ELQ/ELQL Series Slide Cylinder



Main Dimensions

ELQ 25

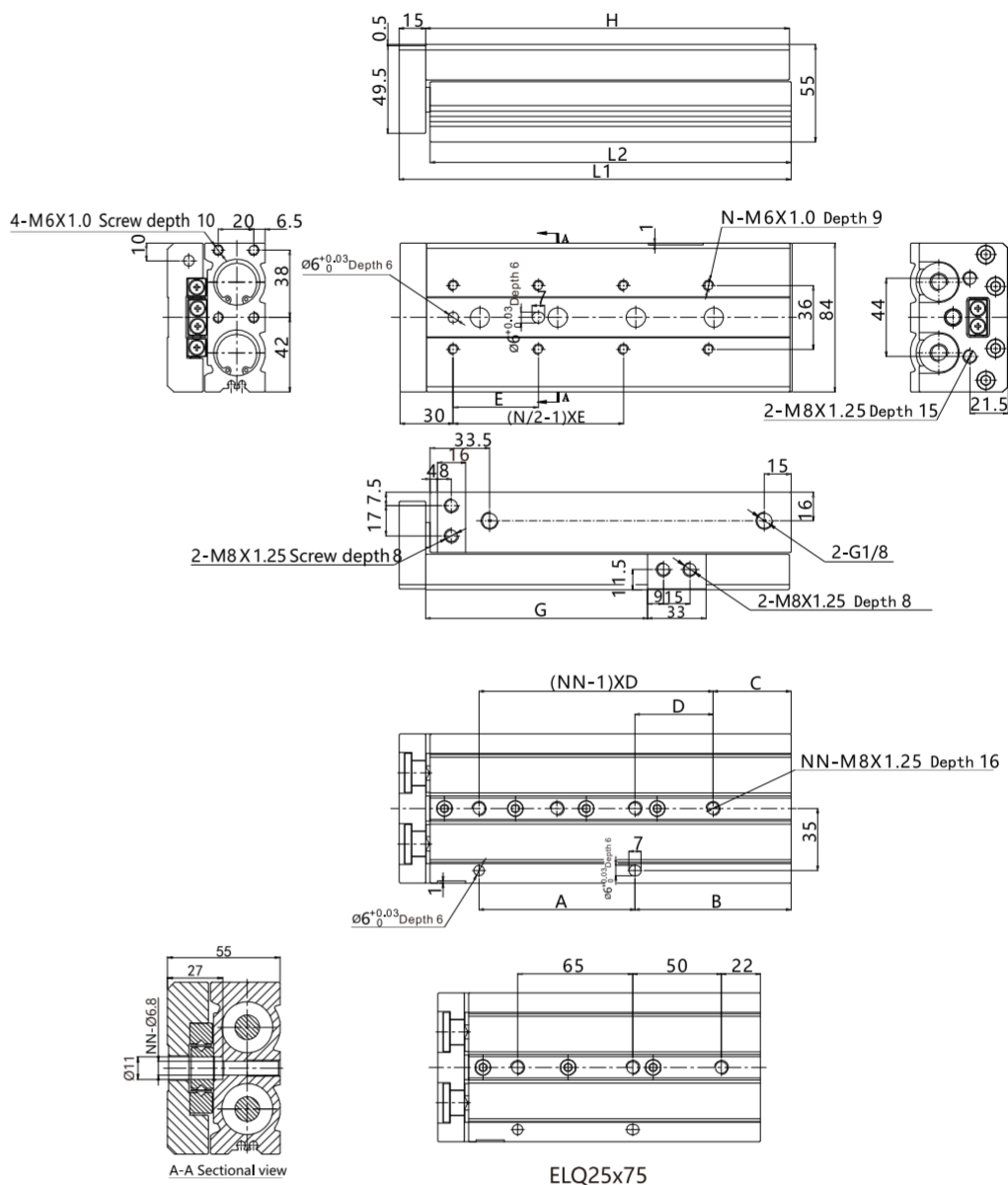

Stroke/Sign	A	B	C	D	E	G	H	L1	L2	N	NN
10	55	23	23	55	55	35	107	123	105.5	4	2
20	55	23	23	55	46	45	107	123	105.5	4	2
30	55	23	23	55	55	55	107	123	105.5	4	2
40	65	23	23	65	65	65	117	133	115.5	4	2
50	80	32	32	80	75	75	141	157	139.5	4	2
75	65	72	See drawing	See drawing	60	100	166	182	164.5	6	3
100	88	88	44	44	48	125	205	221	203.5	8	4
125	132	97	31	66	60	150	258	274	256.5	8	4
150	132	122	56	66	65	175	283	299	281.5	8	4

ELQ/ELQL Series Slide Cylinder



How to Order (for accessories)

Series No.	Type	Bore	Accessory Type
FJ	ELQ : Standard type ELQL : Symmetric type	6	A: With stroke adjusting screws at both ends
		8	AS: With stroke adjusting screws at extension end
		12	AF: With stroke adjusting screws at retraction end
		16	B: With shock absorbers both end
		20	BS: With shock absorber at extension end
25	BF: With shock absorber at retraction end		

Optional Accessories

Accessory type/Bore		6	8	12	16	20	25	
ELQ	Both end	A (stroke adjusting screw)	FJ-ELS6A	FJ-ELQ 8A	FJ-ELQ 12A	FJ-ELQ 16A	FJ-ELQ 20A	FJ-ELS 25A
		B (shock absorber)		FJ-ELQ 8B	FJ-ELQ 12B	FJ-ELQ 16B	FJ-ELQ 20B	FJ-ELS 25B
	Extension end	AS (stroke adjusting screw)	FJ-ELS6AS	FJ-ELQ 8AS	FJ-ELQ 12AS	FJ-ELQ 16AS	FJ-ELQ 20AS	FJ-ELS 25AS
		BS (shock absorber)		FJ-ELQ 8BS	FJ-ELQ 12BS	FJ-ELQ 16BS	FJ-ELQ 20BS	FJ-ELS 25BS
	Retraction end	AF (stroke adjusting screw)	FJ-ELS6AF	FJ-ELQ 8AF	FJ-ELQ 12AF	FJ-ELQ 16AF	FJ-ELQ 20AF	FJ-ELS 25AF
		BF (shock absorber)		FJ-ELQ 8BF	FJ-ELQ 12BF	FJ-ELQ 16BF	FJ-ELQ 20BF	FJ-ELS 25BF

Accessory type/Bore		6	8	12	16	20	25	
ELQL	Both end	A (stroke adjusting screw)	FJ-ELSL6A	FJ-ELQL8A	FJ-ELQL12A	FJ-ELQL16A	FJ-ELQL20A	FJ-ELSL25A
		B (shock absorber)		FJ-ELQL8B	FJ-ELQL12B	FJ-ELQL16B	FJ-ELQL20B	FJ-ELSL25B
	Extension end	AS (stroke adjusting screw)	FJ-ELS6AS	FJ-ELQ8AS	FJ-ELQ12AS	FJ-ELQ16AS	FJ-ELQ20AS	FJ-ELS25AS
		BS (shock absorber)		FJ-ELQ8BS	FJ-ELQ12BS	FJ-ELQ16BS	FJ-ELQ20BS	FJ-ELS25BS
	Retraction end	AF (stroke adjusting screw)	FJ-ELSL6AF	FJ-ELQL8AF	FJ-ELQL12AF	FJ-ELQL16AF	FJ-ELQL20AF	FJ-ELSL25AF
		BF (shock absorber)		FJ-ELQL8BF	FJ-ELQL12BF	FJ-ELQL16BF	FJ-ELQL20BF	FJ-ELSL25BF

Note: A=AS+AF; B=BS+BF

BS(backward shock absorber) is different for Standard type and Symmetric type

Dimension for Accessories

AS (With stroke adjusting screws at extension end)

Accessory on the body

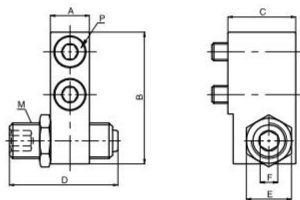

Accessory on the slide

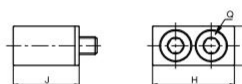

Bore/Sign	Adjustable stroke range	A	B	C	D	E	F	M	P	H	I	J	Q
6	10	7	19	10.5	22.5	8	3	M6X1.0	M2.5 Length 10	12.5	6.5	10.5	M2.5 Length 10
8	10	7	22	15.5	27.5	11	4	M8X1.0	M3 Length 16	16.6	7	15.5	M3 Length 16
12	10	9.5	29	16	27.5	11	4	M8X1.0	M4 Length 14	20.5	9	15	M4 Length 14
16	10	11	36	19	30.5	12.7	5	M10X1.0	M5 Length 18	23	11	18.5	M5 Length 18
20	10	13	45	26	34	19	6	M14X1.5	M6 Length 25	27	12	25.5	M6 Length 25
25	10	16	54	24	34	19	6	M14X1.5	M8 Length 20	33	17	23	M8 Length 20

BS (With shock absorber at extension end)

Accessory on the body

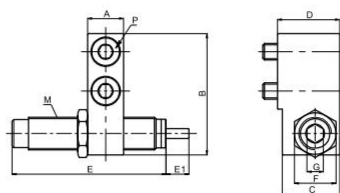

Accessory on the slide

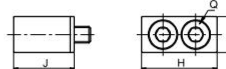

Bore/Sign	A	B	C	D	E	E1	F	M	P	H	I	J	Q
8	7	22	14	15.5	38	6	11	M8X1.0	M3 Length 16	16.6	7	15.5	M3 Length 16
12	9.5	29	14.5	16	38	6	11	M8X1.0	M4 Length 14	20.5	9	15	M4 Length 14
16	11	36	17.5	19	43	7	12.7	M10X1.0	M5 Length 18	23	11	18.5	M5 Length 18
20	13	45	23.5	26	76	12	19	M14X1.5	M6 Length 25	27	12	25.5	M6 Length 25
25	16	54	22	24	76	12	19	M14X1.5	M8 Length 20	33	17	23	M8 Length 20

Main Dimensions

AF (With stroke adjusting screws at retraction end)

Suitable for ELQ

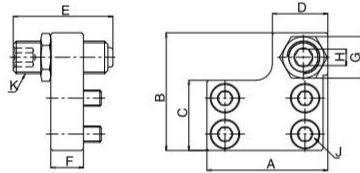

Suitable for ELQL

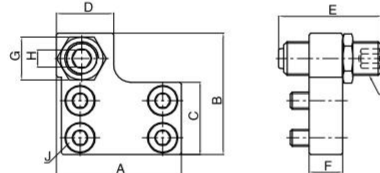

Bore/Sign	Adjustable stroke range	A	B	C	D	E	F	G	H	J	K
6	10	18	19	11.2	8	22.5	6	8	3	M2.5 Length 6	M6X1.0
8	10	24.5	22.2	13.2	13	27.5	8	11	4	M3 Length 8	M8X1.0
12	10	31.5	29	18	15	27.5	8	11	4	M4 Length 8	M8X1.0
16	10	37	36	21.5	17	30.5	10	12.7	5	M5 Length 10	M10X1.0
20	10	45	44	26	23	34	12	19	6	M5 Length 12	M14X1.5
25	10	51	53.5	34	25	34	15	19	6	M6 Length 16	M14X1.5

BF (With shock absorber at retraction end)

Suitable for ELQ

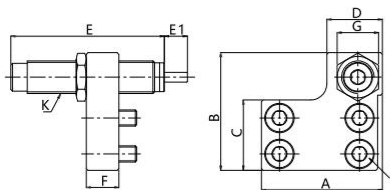

Suitable for ELQL

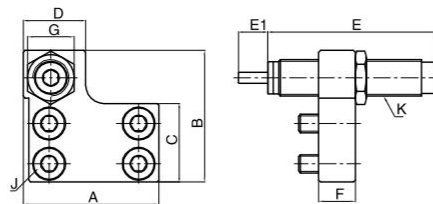

Bore/Sign	A	B	C	D	E	E1	F	G	J	K
8	24.5	22.2	13.2	13	38	6	8	11	M3 Length 8	M8X1.0
12	31.5	29	18	15	38	6	8	11	M4 Length 8	M8X1.0
16	37	36	21.5	17	43	7	10	12.7	M5 Length 10	M10X1.0
20	45	44	26	23	76	12	12	19	M5 Length 12	M14X1.5
25	51	53.5	34	25	76	12	15	19	M6 Length 16	M14X1.5