

ERM

Mini Regulator



Product Features

- Unique structural design, good pressure characteristics, large flow
- Variety of piping options are available
- Two ports position (Ø4, Ø6) are available
- Multiple installation methods

How to order?

Series NO.	Piping Position	Port Size	Bracket Code	Scale Unit
ERM1000F: ERM series mini pressure regulator single front handwheel type	1. Downward Downward 2. Upward Upward 3. Downward Upward 4. Upward Downward	0404 0606 0604	J: No bracket	1:Mpa 2:Bar 3:Psi

Order Example: ERM series mini pressure regulator single front handwheel type, piping position in downward, out downward, port size in out Ø4~Ø4, no bracket, scale unit Mpa, the ERP code is : ERM1000F-1-0404-J-1

Piping Position

Position Mark	In		Out	
	Downward	Upward	Downward	Upward
1	●		●	
2		●		●
3	●			●
4		●	●	

Piping Direction Diagram

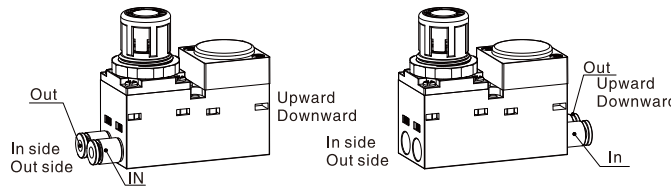

Piping Joint

Mark	Portsize		In		Out	
	4	6	4	6	4	6
0404	●				●	
0606			●			●
0604				●	●	

All joint are straight joint

Internal Structure

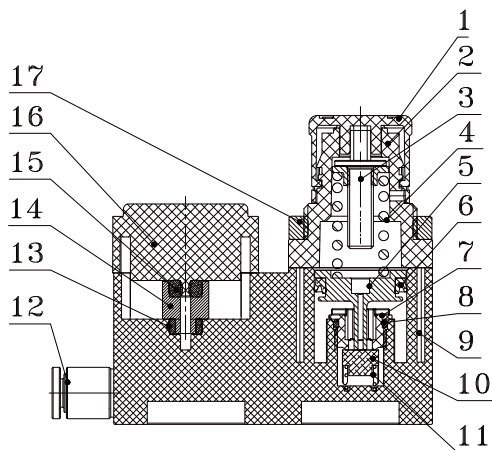

NO.	Part Name	Material	NO.	Part Name	Material
1	Regulating Handle	Plastics	10	Packing Washer	Rubber
2	Valve Cover	Plastics	11	Spring	Stainless Steel
3	Pressure Regulating Screw	Free-Cutting Steel	12	Joint	Stainless Steel + Plastic
4	Spring	SWC	13	Seal	Rubber
5	Piston	Aluminum alloy	14	Vent Pipe	Aluminum alloy
6	Y sealing Ring	Rubber	15	Seal	Rubber
7	Valve Seat	Plastics	16	Pressure Gage	Plastics+Brass
8	O-Ring	Rubber	17	Octagonal Caps	Aluminum Alloy
9	Valve Body	Plastics			

Specifications

Model	ERM1000F
Working Medium	Clean Air
Pressure Regulating Valve Structure	Directly Operated Type
Pressure Mode	Piston
Overflow Structure	Overflow Mode
In External Port	Ø 4 Ø 6
Out External Port	Ø 4 Ø 6
Proof Pressure (Mpa)	1.5
Maximum Working Pressure	1.0
Working Pressure Range(Mpa)	0.05 ~ 0.7
Working Temperature (°C)	5 ~ 60
Weight (g)	97

Pressure Characteristic Parameter Curve

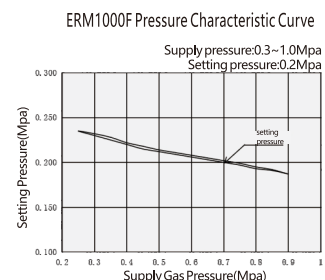

Flow Characteristic Parameter Curve

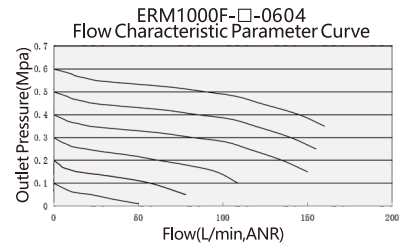
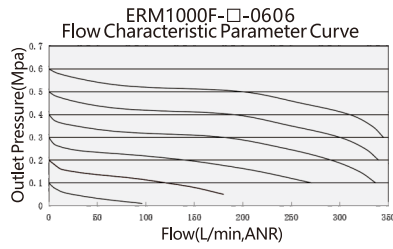
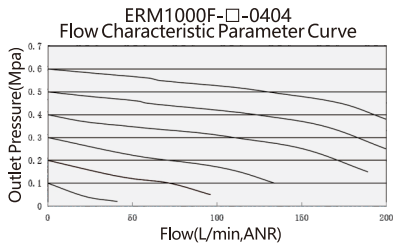

ERM1000F Outline Dimensional Drawing

ERM1000F-1-□

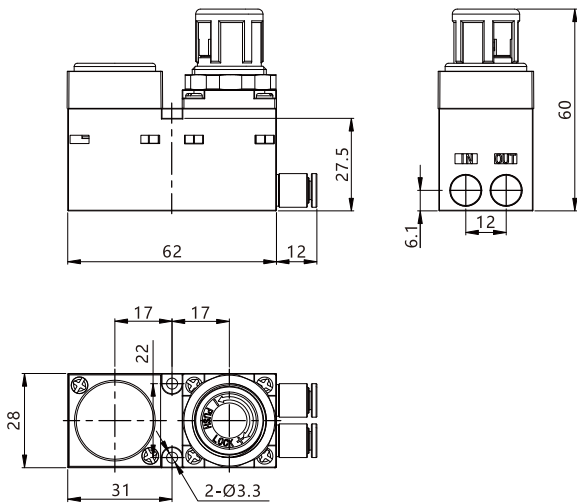

ERM1000F-2-□

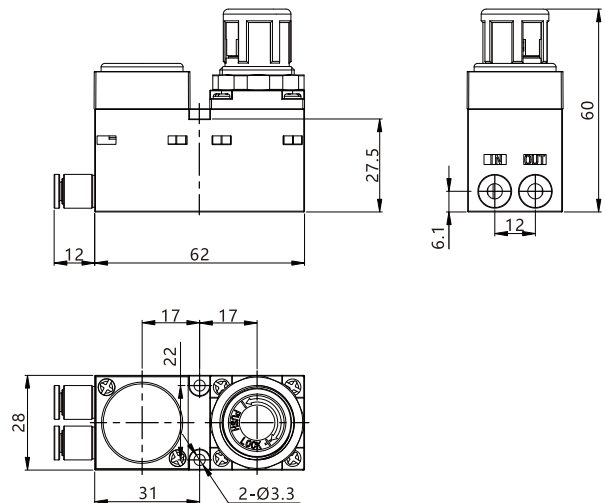

ERM1000F-3-□

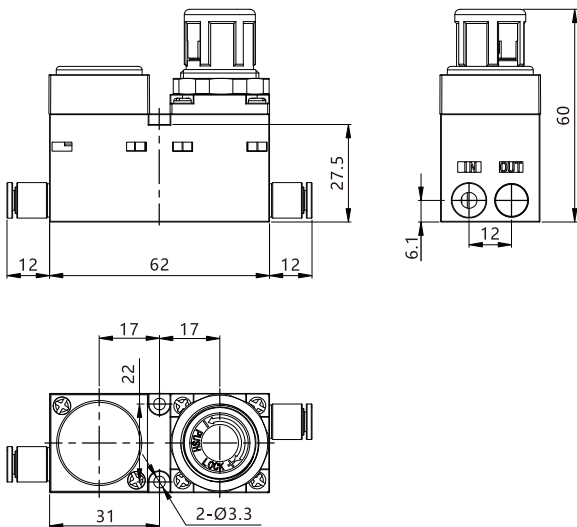

ERM1000F-4-□

